



Demand Side Management with LONWORKS[®] Power Line Transceivers

December 1996

LONWORKS Engineering Bulletin

Introduction

Demand side management (DSM) is the process of shifting the demand for energy from expensive peak periods to times when energy can be most efficiently and inexpensively delivered to customers. Through a combination of economic incentives, such as variable energy rates based on time-of-day usage, and forced service interruptions of appliances such as air conditioner and spa heaters (shedding), utilities shift energy consumption into off-peak hours when generating capacity is not at a premium. Off-peak energy consumption provides more efficient use of energy generating capacity, and prevents—or at least forestalls—the need to build expensive new generating capacity to meet peak loads.

This document describes the use of LONWORKS for residential DSM applications. LONWORKS provides a highly refined and reliable communication scheme based on an open protocol, LONTALK[®], that supports bi-directional communications, can communicate over virtually any medium, and can be installed and maintained easily using a client-server network management architecture. These features, and specifically the availability of a robust power line signaling technology, make LONWORKS ideal for residential DSM applications. The sections that follow include an overview of DSM systems, a description of the LONWORKS PLT-21 Power Line Transceiver, a review of the electrical wiring in a typical North American residence, and a detailed analysis of the coupling circuits needed to implement a reliable power line signaling system.

DSM Overview

DSM requires a sophisticated control and communication infrastructure in order to function. The control network must carry rate information and load shedding commands from the utilities to the home or building occupants, and return customer inquiries and consumption information needed to calculate utility bills. If additional services such as remote control and security monitoring are supported then these must be transmitted as well.

Large DSM systems place a heavy burden on the network management architecture used to install, monitor, control, and maintain hundreds of thousands of electronic meters, customer interface units, load shed devices, and related equipment. Typically there are many technicians that need simultaneous access to the network management infrastructure as they commission new devices, modify network

operation, and service customer requests. The overall communication and control infrastructure is summarized in figure 1.

A variety of communications media may be used between the utility and the customer's home or building depending on throughput requirements, the presence of an existing communication plant, and the future growth plans of the network. Power line signaling is typically used for connecting to the customer's meter, user interface, load shed modules, and automation system components due to its inherently low cost of installation, though twisted pair wiring and radio signaling may also be used (figure 2).

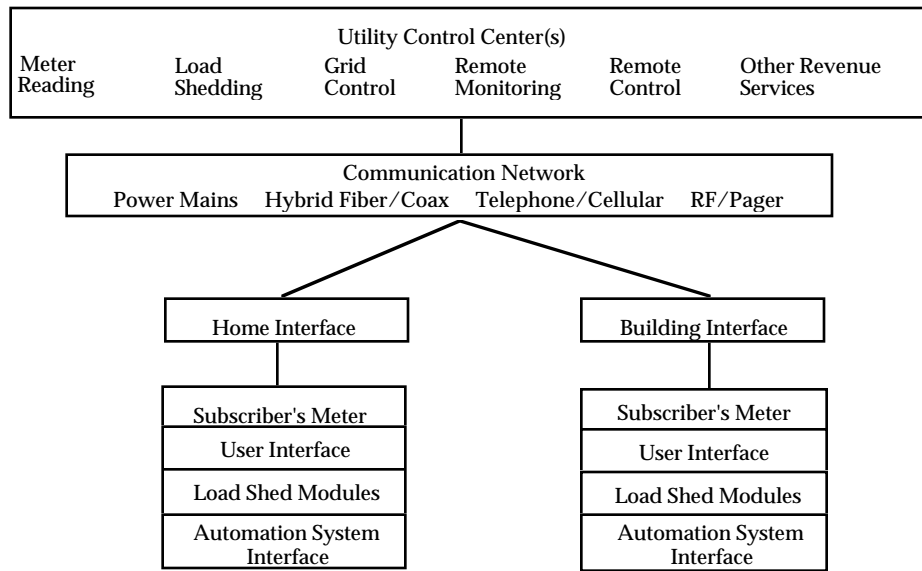

Figure 1 DSM Infrastructure

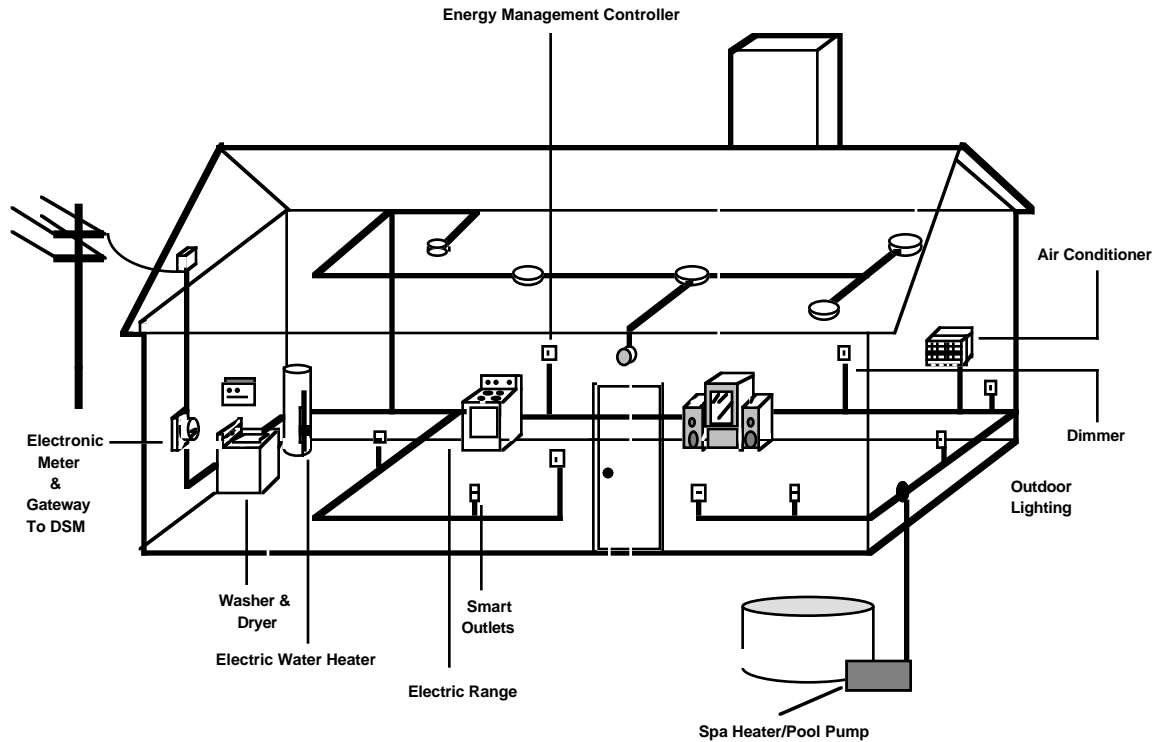

Figure 2 Typical DSM Control Network

LONWORKS Power Line Transceivers

LONWORKS control networks are used worldwide by utilities for intelligent DSM networks in part because of the availability of reliable power line transceivers that signal over any AC or DC power mains wiring (figure 3). Power line signaling eliminates the need for additional communications cabling, and both reduces the expense and simplifies the task of retrofitting existing homes and buildings.

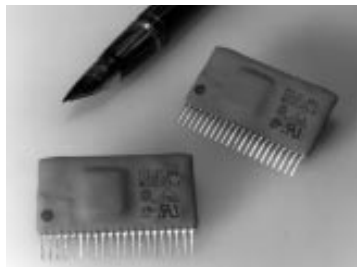

Figure 3 PLT-21 Power Line Transceiver

The LONWORKS transceiver used for DSM applications is the PLT-21 Power Line Transceiver. Designed to meet FCC, Industry Canada, and European CENELEC

EN50065-1 requirements, the PLT-21 transceiver uses digital signal processing for adaptive carrier and data correlation, impulse noise cancellation, tone rejection, and low overhead error correction (figure 4). These advancements in signaling technology enable the PLT-21 transceiver to communicate reliably in the presence of consumer electronics, power line intercoms, motor noise, electronic ballasts, dimmers, and other typical sources of interference.

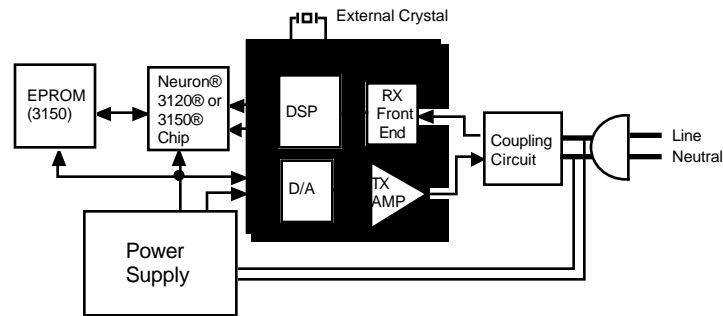

Figure 4 PLT-21 Power Line Transceiver Block Diagram

The PLT-21 transceiver is a backward-compatible replacement for the highly successful PLT-20 Power Line Transceiver, and includes several new features to improve signaling and significantly lower node cost. One of the new features is an internal amplifier that includes a selectable +6dB signal boost mode. This feature increases the output signal of the transceiver to 7V peak-to-peak (p-p). The 1 Ω output impedance and 1A p-p current capability of the amplifier allow it to drive high output levels into low impedance circuits while drawing less total current than did the PLT-20 transceiver.

The PLT-21 communications signals are injected into the power mains by capacitively coupling the output of the transceiver through a coupling circuit. The coupling circuit attenuates the large low-frequency AC mains' power (typically 50Hz or 60Hz) while passing the transceiver's communication signal. The selection of the components used in the coupling circuit, as well as the availability of Line (L), Earth (E), and Neutral (N) determine how well a coupling circuit will work in any given application. The *PLT-21 Power Line Transceiver User's Guide* details the theory behind coupling circuit design, and presents a family of general use coupling circuits for various applications. Later in this document additional specialized coupling circuits recommended for specific DSM devices will be presented.

Typical Residential Wiring

The remainder of this document discusses the application of PLT-21 Power Line Transceiver in a residential DSM application. The "house" described is typical of a single family residence in North America, and may or may not be applicable to locales outside of North America.

Figure 5 illustrates the power mains wiring in a typical house, including the voltages typically found at normal outlets and wiring devices. This house has two power phases, Line 1 (L1) and Line 2 (L2), also referred to as two poles of a single phase, and a Neutral (N) line. These are brought into the house from the utility's distribution transformer outside the house. L1 and L2 are 180° offset and 120VAC each with respect to N. The L1-to-L2 voltage is 240VAC.

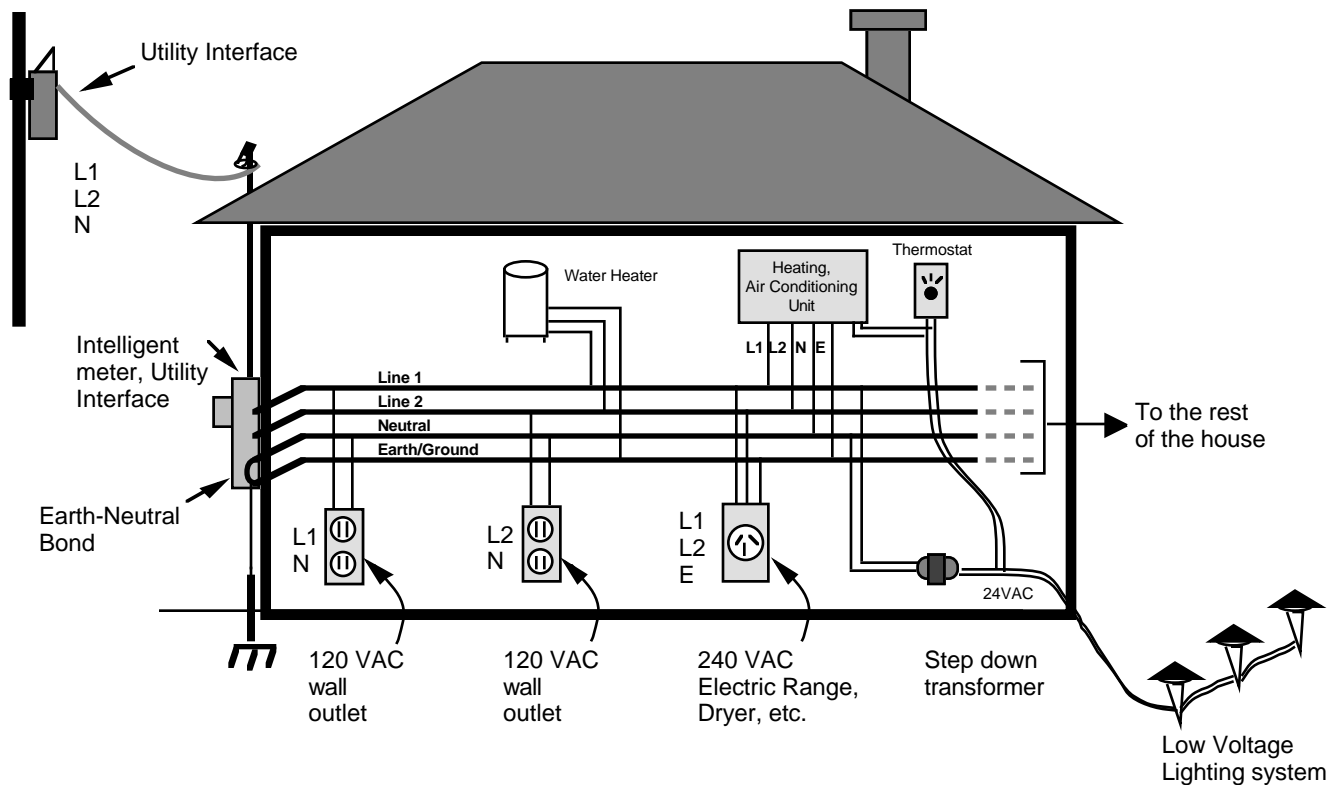

Figure 5 Power Line Wiring In A Typical House

If this house was constructed after the 1960s, it would have a safety Earth (E) connection available at every outlet. Homes constructed before 1960 typically only have N and either L1 or L2 available except at 240VAC outlets where E is generally available (but N often is not available). E and N are connected together, or bonded, at the main electrical panel but are treated in this document as separate circuits. Given the large number of homes that lack E at every outlet, the discussion which follows assumes that N and either L1 or L2 is available at every outlet and E is available only at 240VAC service connections.

Establishing Reliable Power Line Communications

In general, optimizing the performance of a power line transceiver involves a combination of proper node design and the selection of an optimal coupling circuit. Proper node design is covered in detail in the PLT-21 Users Guide.

Figure 6 presents the coupling techniques that have been used successfully to establish reliable power line signaling in homes. Each coupling circuit is identified with a number which refers to the schematic and parts list associated with that circuit. In some cases the reader is referred to a specific user's guide for the schematic and parts. Depending on the specific DSM application, one, many, or all of these circuits may be used in a home.

The choice of coupling circuits for each individual DSM device communicating on the power mains is the key to installing a robust, reliable system. For DSM system applications, the high cost of service calls and the need for the highest degree of customer satisfaction make it prudent to maximize system communications margins where possible. The coupling circuits described here have been optimized for maximum performance by taking advantage of the following key concepts.

- The combination of coupling methods has been chosen to maximize communication margin between single phase devices and two-phase devices. The coupling circuits in this document avoid the 6dB (or more) signal loss that would occur if one attempted to communicate between a device with a coupling circuit connected only between L1 and L2 (i.e. no N or E connection) and a device whose coupling circuit was connected to L1 or L2 and N. This loss is significant in designing a DSM system with the level of reliability required in mass deployment. This loss is avoided in the case of two phase loads (such as water heaters and electric ranges) that connect to both phases but do not have a neutral connection. Such loads do, however, have (by code) an Earth connection. By coupling to the two lines relative to earth and taking advantage of the E-N bond present at the house power entry, robust communication between the two phase load and a single phase node (perhaps a user interface plugged into a wall socket) is maintained.
- Each coupling circuit has been “tuned” for its specific intended location. In order to couple maximum transmit signal onto the mains, each coupling circuit employs a resonant circuit (typically L2 and C1) that is tuned to have very low impedance at the PLT-21 communication frequency. The value of L2 is “pre-tuned” in order to take in to account the typical wiring inductance that would be present at the location where a particular DSM device would be installed. Thus

the “pre-tuning” of the resonant circuit is different for a DSM device located near a breaker panel, which is a non-inductive load point, than at a distribution transformer, which is separated from the home by mains wiring that presents a significant series inductance.

The same issue of 6dB (or more) loss between a two phase connection and a single phase connection is present when adding powerline communication to an electric meter. In this case the loss is avoided by adding a “Neutral pigtail” to the meter which is screwed into the meter sheet metal housing. The meter sheet metal housing is always tied to Neutral/Earth, thus the meter coupling circuit will be connected to both phases relative to Neutral/Earth and avoid the loss in communication system margin.

- Phase coupling has been added to minimize signal loss between single phase devices on different phases. Because the distribution transformer windings effectively isolate communication signal frequencies between phase 1 and phase 2, communication between two single phase devices on different phases becomes possible only due to the inductive coupling between the two phases that occurs due to the proximity of the two wires as they run between the distribution transformer and the home. A communications signal crossing from one phase to the other via this inductive coupling is subject to 10-30 dB of attenuation. The extra 6dB of transmit signal power available in the PLT-21 helps to mitigate this loss and is sufficient for many consumer applications. Once again, for DSM system applications the high cost of service calls and the need for the highest degree of customer satisfaction make it prudent to maximize system communication margin where possible, thus the DSM coupling circuits in this document show the addition of phase coupling circuits where appropriate.
- A means for devices on L1 or L2 and low voltage devices (e.g., 24VAC) to inter-communicate has been provided. Since 60Hz step down transformers highly attenuate power line communication signals, coupling circuits that bridge these transformers have been designed for systems that extend communications onto a low voltage home network. Both stand alone versions are presented as well as a version that combines both mains and low voltage coupling. Also, an example of a low voltage coupling circuit is presented.

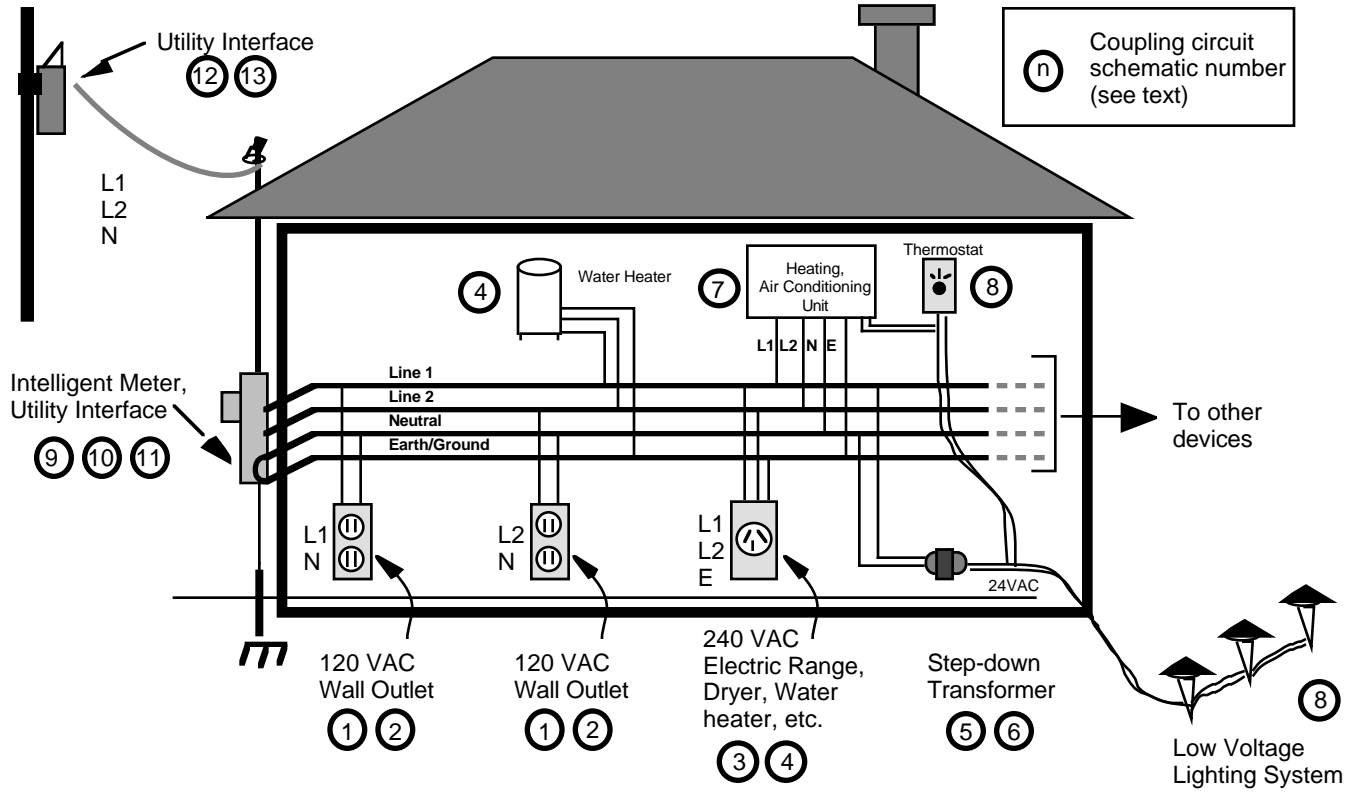

Figure 6 Typical Coupling Techniques

Coupling Circuits

The following circuits are intended to highlight the detail of the coupling circuits shown in figure 6. For each circuit a parts list, including vendor names and part numbers, is given. The circuits are arranged sequentially by the schematic number.

The schematics shown in this document have been optimized for use with the PLT-21 transceiver. As an alternative, the PLT-21 transceiver may be used with comparable PLT-20 coupling circuits. Note, however, that the PLT-20 transceiver **may not** be used with the PLT-21 coupling circuits shown below.

1. Line-to-Neutral, Non-Isolated Coupling Circuit

Use for any device that does not require an isolated 120VAC mains connection and requires Line-to-Neutral coupling. Refer to example 1 in the *PLT-21 Power Line Transceiver User's Guide* for the schematic and parts list.

2. Line-to-Neutral, Transformer-Isolated Coupling Circuit

Use for any device that requires an isolated 120VAC mains connection and requires Line-to-Neutral coupling. Refer to example 2 in the *PLT-21 Power Line Transceiver User's Guide* for the schematic and parts list.

3. 240VAC Load, Non-Isolated Coupling Circuit with Phase Coupling

The non-isolated 240VAC load coupling circuit shown in figure 7 is intended for use with two-phase (240VAC) devices where Neutral may not be present and Earth is present, e.g., load control modules connected to electric water heaters, air conditioners, spa and pool heaters, electric dryers, and electric ranges. Table 1 lists component values and recommended suppliers/part numbers where appropriate.

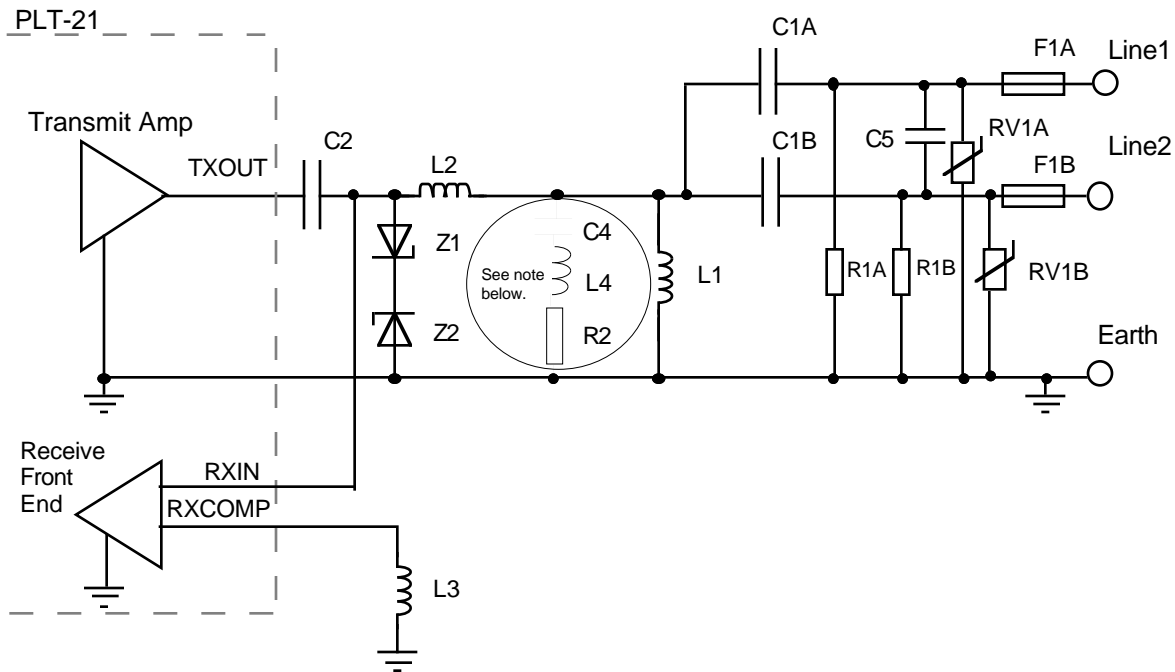

Note: This optional circuit should be added to nodes with a nominal $V_A < 12V$ or nodes that contain a triac or SCR load switching device.

Figure 7 240VAC Load Non-Isolated Phase Coupling Circuit Schematic

Table 1 240VAC Load, Non-Isolated Phase Coupling Component Values

Comp	Value	Specifications	Vendor/Part #
C1A, C1B	0.047 μ F	$\pm 10\%$, ≥ 250 VDC, metalized polyester ⁽¹⁾	Matsushita Electric/ECQ-E2473KF
C2	0.82 μ F	$\pm 5\%$, ≥ 50 VDC, metalized polyester	Matsushita Electric/ECQ-V1H824JL
C4	0.1 μ F	$\pm 5\%$, ≥ 50 VDC	AVX /SR205C104JAA
C5	0.47 μ F	$\pm 10\%$, ≥ 400 VDC, metalized polyester ⁽¹⁾	Matsushita Electric/ECQ-E4474KF
F1A, F1B	6A	125VAC, slow blow ⁽²⁾	
L2	12 μ H	$\pm 10\%$, $I_{max} \geq 30$ mA, $R_{DC} \leq 50\Omega$	TAIYO YUDEN/LAL05NA120K
L1, L3, L4	1.0mH	$\pm 10\%$, $I_{max} \geq 30$ mA, $R_{DC} \leq 50\Omega$	TAIYO YUDEN/LAL03NA102K
R2	82 Ω -L4 R_{DC} ⁽³⁾	$\pm 5\%$, 1/4W	
R1A, R1B	1M Ω	$\pm 5\%$, 1/4W, max working volt ≥ 200 VDC ⁽⁴⁾	
RV1A, RV1B	150VAC (240VDC)	Surge rating depends on application ⁽⁵⁾	Matsushita Electric/ERZ-V14D241
Z1, Z2	7.5V	$\pm 5\%$ Zener, 180W surge for 8.3ms	1N5343B

- (1) In some applications an X2 safety rated capacitor may be required. Consult applicable safety standards.
- (2) In some applications a fuse may not be required. Consult applicable safety standards.
- (3) The value of R2 should be selected so that the series combination of the DC resistance of L4 and R2 is equal to 82 Ω .
- (4) The working voltage rating of R1A, R1B may be achieved by using two 470k Ω resistors in series, each with a working voltage rating of at least half of the value listed above. In addition, the peak power and peak voltage ratings of R1A, R1B must be chosen to meet the high-pot testing requirements of the application.
- (5) High-pot manufacturing tests must be performed prior to installation of RV1A and RV1B. High-pot testing between line and earth is usually performed at voltages above the varistor clamping voltage, and the test will fail if the varistors clamp during testing. In addition, a DC high-pot tester must be used to avoid excessive current flow through C1A and C1B.

4. 240VAC Load, Transformer-Isolated Coupling Circuit with Phase Coupling

The transformer-isolated 240VAC load coupling circuit shown in figure 8 is intended for use with two-phase (240VAC) devices where Neutral may not be present and Earth is present, e.g., load control modules connected to electric water heaters, air conditioners, spa and pool heaters, electric dryers, and electric ranges. Table 2 lists component values and recommended suppliers/part numbers where appropriate.

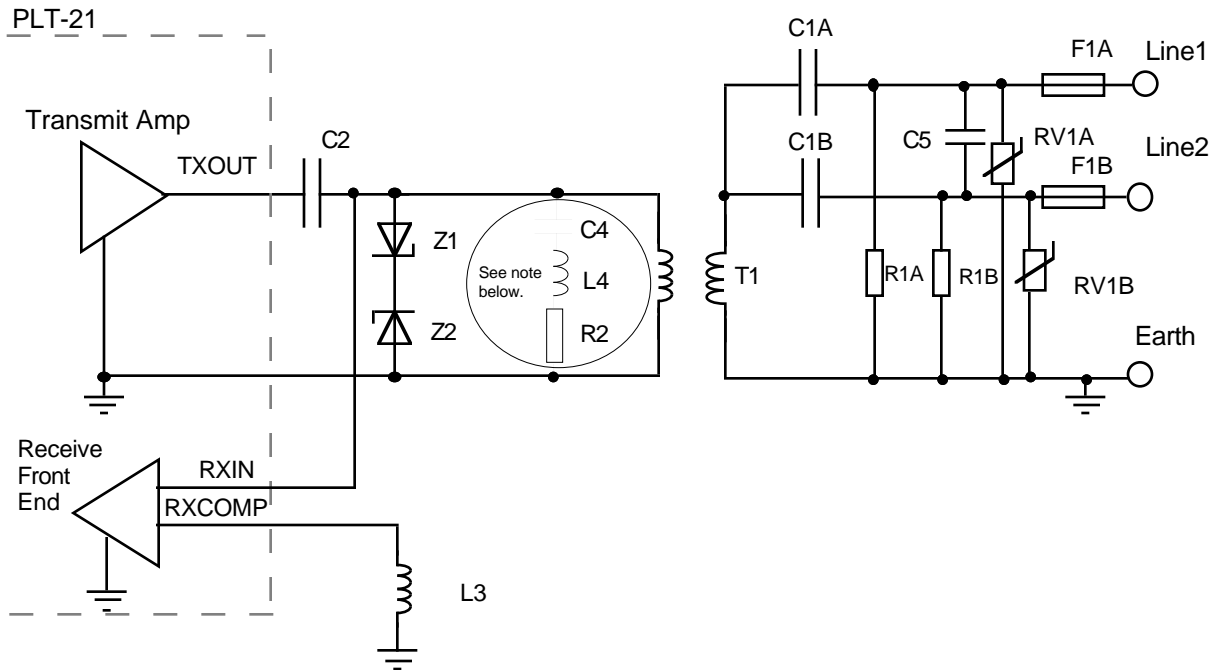

Note: This optional circuit should be added to nodes with a nominal $V_A < 12V$ or nodes that contain a triac or SCR load switching device.

Figure 8 240VAC Load Transformer-Isolated Phase Coupling Circuit Schematic

Table 2 240VAC Load, Transformer-Isolated Phase Coupling Component Values

Comp	Value	Specifications	Vendor/Part #
C1A, C1B	0.047 μ F	$\pm 10\%$, ≥ 250 VDC, metalized polyester ⁽¹⁾	Matsushita Electric/ECQ-E2473KF
C2	0.82 μ F	$\pm 5\%$, ≥ 50 VDC, metalized polyester	Matsushita Electric/ECQ-V1H824JL
C4	0.1 μ F	$\pm 5\%$, ≥ 50 VDC	AVX /SR205C104JAA
C5	0.47 μ F	$\pm 10\%$, ≥ 400 VDC, metalized polyester ⁽¹⁾	Matsushita Electric/ECQ-E4474KF
F1A, F1B	6A	125VAC, slow blow ⁽²⁾	
L3, L4	1.0mH	$\pm 10\%$, $I_{max} \geq 30$ mA, $R_{DC} \leq 50\Omega$	TAIYO YUDEN / LAL03NA102K
R2	82 Ω -L4 R_{DC} ⁽³⁾	$\pm 5\%$, 1/4W	
R1A, R1B	1M Ω	$\pm 5\%$, 1/4W, max working volt ≥ 200 VDC ⁽⁴⁾	
RV1A, RV1B	150VAC (240VDC)	Surge rating depends on application ⁽⁵⁾	Matsushita Electric/ERZ-V14D241
T1		See Appendix A	
Z1, Z2	7.5V	$\pm 5\%$ Zener, 180W surge for 8.3ms	1N5343B

- (1) In some applications an X2 safety rated capacitor may be required. Consult applicable safety standards.
- (2) In some applications a fuse may not be required. Consult applicable safety standards.
- (3) The value of R2 should be selected so that the series combination of the DC resistance of L4 and R2 is equal to 82 Ω .
- (4) The working voltage rating of R1A, R1B may be achieved by using two 470k Ω resistors in series, each with a working voltage rating of at least half of the value listed above. In addition, the peak power and peak voltage ratings of R1A, R1B must be chosen to meet the high-pot testing requirements of the application.
- (5) High-pot manufacturing tests must be performed prior to installation of RV1A and RV1B. High-pot testing between line and earth is usually performed at voltages above the varistor clamping voltage, and the test will fail if the varistors clamp during testing. In addition, a DC high-pot tester must be used to avoid excessive current flow through C1A and C1B.

5. 24VAC-to-240VAC Line1, Line2-to-Earth, Transformer-Isolated Passive Signal Coupler

The transformer-isolated circuit shown in figure 9 is intended to couple signals originating from one or more transceivers communicating on a 24VAC line onto 120/240VAC wiring at a location where Line1, Line2, and Earth are available and Neutral may not be present. Table 3 lists component values and recommended suppliers/part numbers where appropriate.

It is important that any power supplies connected to the 24VAC lines do not load the power line communication signal. For instance both DC-to-DC converters and simple rectifier/filter/regulator power supplies have the potential to significantly attenuate the communication signal. The guidelines for reducing the loading effects of power supplies are presented in the *PLT-21 Power Line Transceiver User's Guide*.

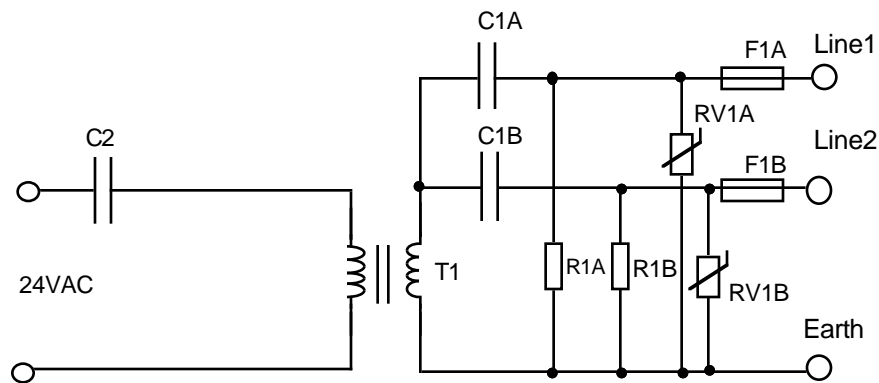

Figure 9 24VAC to 240VAC L1 L2-to-E, Transformer-Isolated Passive Signal Coupler Schematic

Table 3 24VAC to 240VAC L1 L2-to-E, Transformer-Isolated Passive Coupler
Component Values

Comp	Value	Specifications	Vendor/Part #
C1A, C1B	0.047 μ F	\pm 10%, \geq 250VDC, metalized polyester ⁽¹⁾	Matsushita Electric/ECQ-E2473KF
C2	0.47 μ F	\pm 5%, \geq 50VDC, metalized polyester	Matsushita Electric/ECQ-V1H474JL
F1A, F1B	6A	125VAC, slow blow ⁽²⁾	
R1A, R1B	1M Ω	\pm 5%, 1/4W, max working volt \geq 200VDC ⁽³⁾	
RV1A, RV1B	150VAC (240VDC)	Surge rating depends on application ⁽⁴⁾	Matsushita Electric/ERZ-V14D241
T1		See Appendix B	

- (1) In some applications an X2 safety rated capacitor may be required. Consult applicable safety standards.
- (2) In some applications a fuse may not be required. Consult applicable safety standards.
- (3) The working voltage rating of R1A, R1B may be achieved by using two 470k Ω resistors in series, each with a working voltage rating of at least half of the value listed above. In addition, the peak power and peak voltage ratings of R1A, R1B must be chosen to meet the high-pot testing requirements of the application.
- (4) High-pot manufacturing tests must be performed prior to installation of RV1A and RV1B. High-pot testing between line and earth is usually performed at voltages above the varistor clamping voltage, and the test will fail if the varistors clamp during testing. In addition, a DC high-pot tester must be used to avoid excessive current flow through C1A and C1B.

6. 24VAC-to-120VAC L-to-N, Transformer-Isolated Passive Signal Coupler

The transformer-isolated coupling circuit shown in figure 10 is intended to couple signals originating from one or more transceivers communicating on a 24VAC line onto 120VAC wiring at a location where Line and Neutral are available and Earth may not be present. Table 4 lists component values and recommended suppliers/part numbers.

For maximum operating margin when communicating across power phases, installation of a signal phase coupler at or near the residence power entry panel (either coupling circuit 11 for a stand-alone phase coupler or as contained in coupling circuits 9 and 10) is recommended for use with this single phase 24VAC to 120VAC coupler.

It is important that any power supplies connected to the 24VAC lines do not load the power line communication signal. For instance both DC-to-DC converters and simple rectifier/filter/regulator power supplies have the potential to significantly attenuate the communication signal. The guidelines for reducing the loading effects of power supplies are presented in the *PLT-21 Power Line Transceiver User's Guide*.

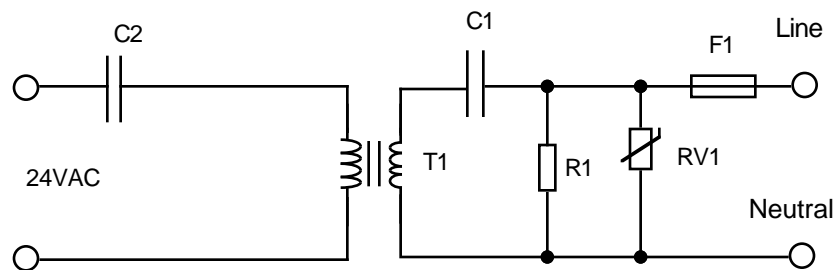

Figure 10 24VAC-to-120VAC L-to-N, Transformer-Isolated Passive Signal Coupler Schematic

Table 4 24VAC-to-120VAC L-to-N, Transformer-Isolated Passive Signal Coupler
Component Values

Comp	Value	Specifications	Vendor/Part #
C1	0.1 μ F	\pm 10%, \geq 250VDC, metalized polyester ⁽¹⁾	Matsushita Electric/ECQ-EZ104KF
C2	0.47 μ F	\pm 5%, \geq 50VDC, metalized polyester	Matsushita Electric/ECQ-V1H474JL
F1	6A	125VAC, slow blow ⁽²⁾	
R1	1M Ω	\pm 5%, 1/4W, max working volt \geq 200VDC ⁽³⁾	
RV1	150VAC (250VDC)	Surge rating depends on application	Matsushita Electric /ERZ-V14D241
T1		See Appendix B	

- (1) In some applications an X2 safety rated capacitor may be required. Consult applicable safety standards.
- (2) In some applications a fuse may not be required. Consult applicable safety standards.
- (3) The working voltage rating of R1 may be achieved by using two 470k Ω resistors in series, each with a working voltage rating of at least half of the value listed above.

7. Combined 120VAC and 24VAC, Transformer-Isolated Coupling Circuit

In some applications it is useful to be able to couple transceiver communication signals to both the AC power mains and a low-voltage network such as the 24VAC wiring present in many homes. For example, there is often a need to communicate from an air conditioner to both an electric meter and a low-voltage thermostat. If the 24VAC lines are co-located with a mains-connected transceiver then the simple coupling method shown in figure 11 below should be used. Table 5 lists component values and recommended suppliers/part numbers where appropriate.

For maximum operating margin when communicating across power phases, installation of a signal phase coupler at or near the residence power entry panel (either coupling circuit 11 for a stand-alone phase coupler or as contained in coupling circuits 9 and 10) is recommended for use with this single phase 24VAC to 120VAC coupler.

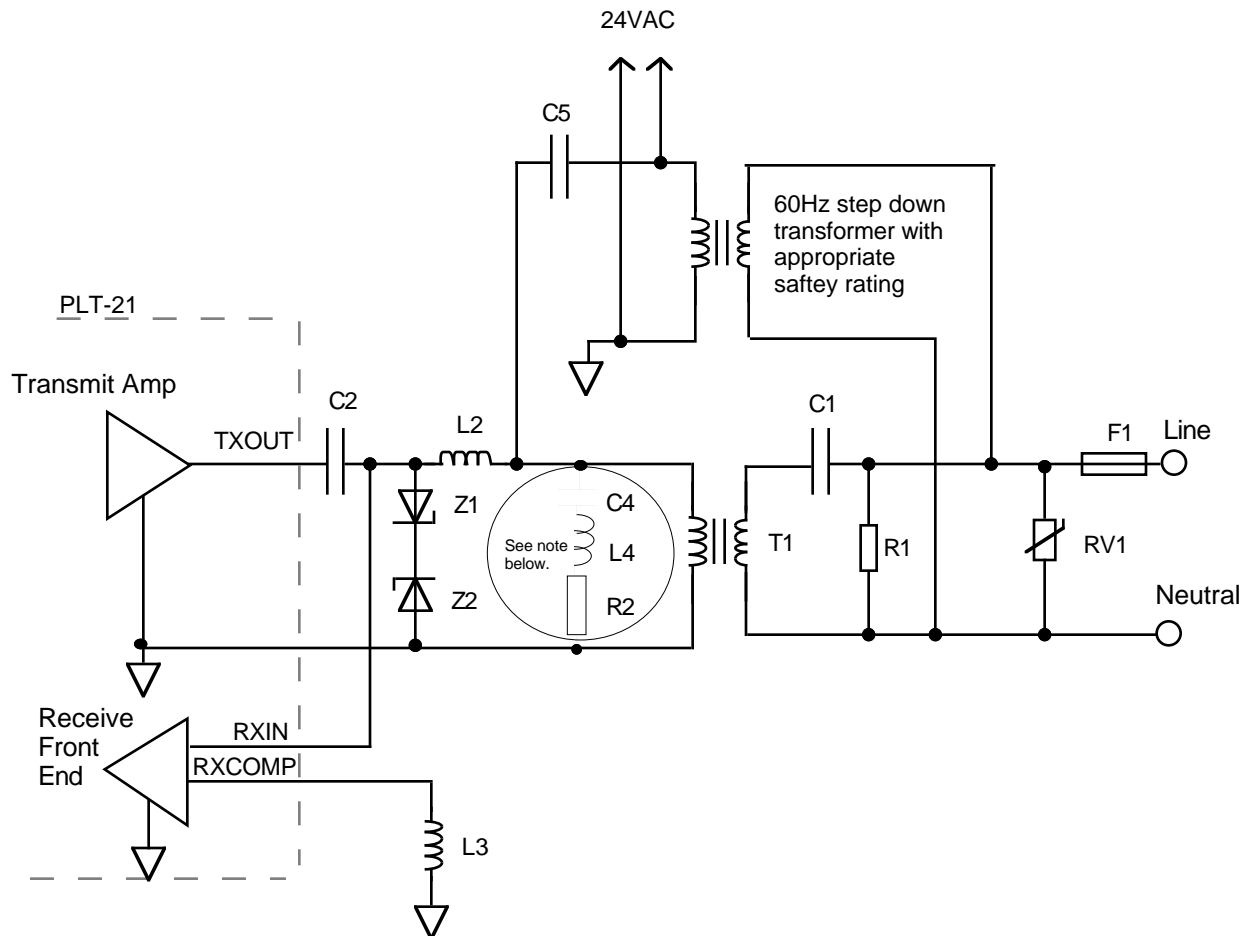

Note: This optional circuit should be added to nodes with a nominal $V_A < 12V$ or nodes that contain a triac or SCR load switching device.

Figure 11 Combined 120VAC and 24VAC, Transformer-Isolated Coupling Circuit Schematic

It is important that any power supplies connected to the 24VAC lines do not load the power line communication signal. For instance both DC-to-DC converters and simple rectifier/filter/regulator power supplies have the potential to significantly attenuate the communication signal. The guidelines for reducing the loading effects of power supplies are presented in the *PLT-21 Power Line Transceiver User's Guide*.

Table 5 Combined 120VAC and 240VAC, Transformer-Isolated Coupling Circuit Component Values

Comp	Value	Specifications	Vendor/Part #
C1	0.1 μ F	$\pm 10\%$, ≥ 250 VDC, metalized polyester ⁽¹⁾	Matsushita Electric/ECQ-E2104KF
C2	0.82 μ F	$\pm 5\%$, ≥ 50 VDC, metalized polyester	Matsushita Electric/ECQ-V1H824JL
C4	0.1 μ F	$\pm 5\%$, ≥ 50 VDC	AVX /SR205C104JAA
C5	0.47 μ F	$\pm 5\%$, ≥ 50 VDC, metalized polyester	Matsushita Electric/ECQ-V1H474JL
F1	6A	125VAC, slow blow ⁽²⁾	
L3, L4	1.0mH	$\pm 10\%$, $I_{max} \geq 30$ mA, $R_{DC} \leq 50\Omega$	TAIYO YUDEN /LAL03NA102K
L2	12 μ H	$\pm 10\%$, $I_{max} \geq 500$ mA, $R_{DC} \leq 0.3\Omega$	TAIYO YUDEN/LAL05NA120K
R2	82 Ω -L4RDC ⁽³⁾	$\pm 5\%$, 1/4W	
R1	1M Ω	$\pm 5\%$, 1/4W, max working volt ≥ 200 VDC ⁽⁴⁾	
RV1	150VAC (240VDC)	Surge rating depends on application	Matsushita Electric/ERZ-V14D241
T1		See Appendix B	
Z1, Z2	7.5V	$\pm 5\%$ Zener, 180W surge for 8.3ms	1N5343B

- (1) In some applications an X2 safety rated capacitor may be required. Consult applicable safety standards.
- (2) In some applications a fuse may not be required. Consult applicable safety standards.
- (3) The value of R2 should be selected so that the series combination of the DC resistance of L4 and R2 is equal to 82 Ω .
- (4) The working voltage rating of R1 may be achieved by using two 470k Ω resistors in series, each with a working voltage rating of at least half of the value listed above.

8. 24VAC, Non-Isolated Coupling Circuit

The non-isolated, 24VAC coupling circuit shown in figure 12 is intended for coupling the transceiver to existing, low-voltage (24VAC) wiring within a house. Typically a passive coupler is used to couple communications signals between the low-voltage, 24VAC wiring and the 120/240VAC wiring elsewhere in the house (see coupling circuit 6). Unlike the other coupling circuits presented in this document, the non-isolated, 24VAC coupling circuit does not use resonant coupling and has been simplified considerably to reflect the less demanding, low-voltage environment. Table 6 lists component values and recommended suppliers/part numbers where appropriate.

Care must be taken to ensure that power supplies connected to the 24VAC lines do not load the PLT-21 communications signal. For example, both DC-to-DC converters and simple rectifier/filter/regulator power supplies have the potential to significantly attenuate the PLT-21 communications signal. The guidelines for reducing the loading effects of power supplies are presented in Chapter 5 of the *PLT-21 Power Line Transceiver User's Guide*.

It is assumed that nodes communicating on the 24VAC lines are powered from the 24VAC line and are floating.

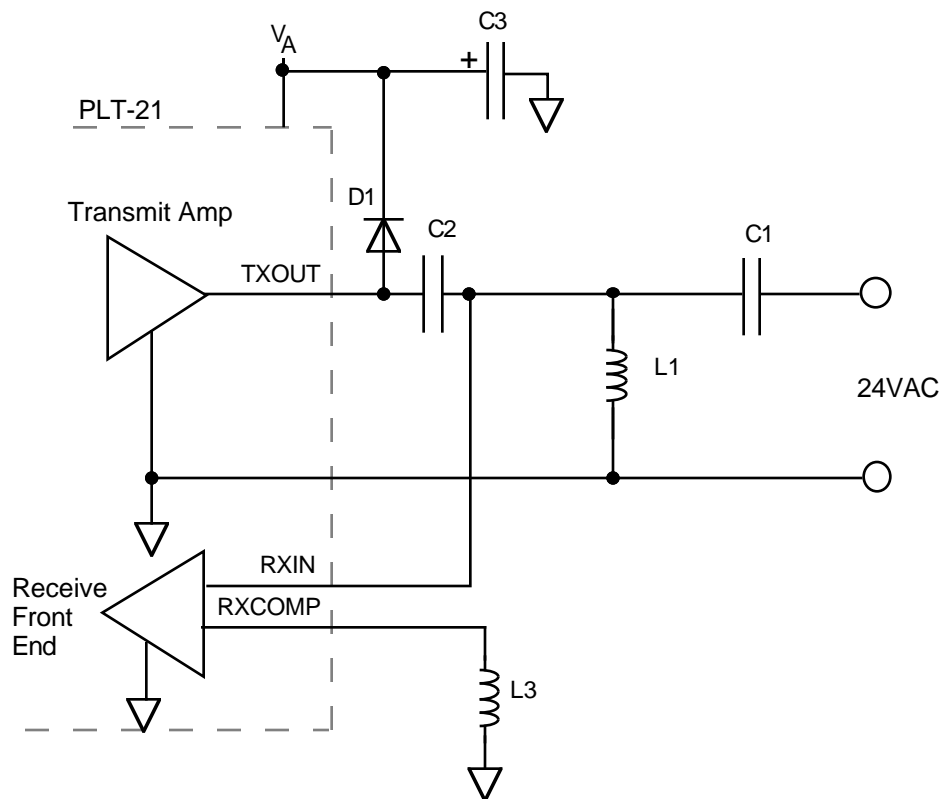

Figure 12 24VAC, Non-Isolated Coupling Circuit Schematic

Table 6 24VAC, Non-Isolated Coupling Circuit Component Values

Comp	Value	Specifications	Vendor/Part #
C1	0.47 μ F	$\pm 10\%$, ≥ 50 VDC, metalized polyester	Matsushita Electric/ECQ-V1H474JL
C2	0.82 μ F	$\pm 5\%$, ≥ 50 VDC, metalized polyester	Matsushita Electric/ECQ-V1H824JL
C3	$\geq 120\mu$ F	$\pm 20\%$, 16VDC, aluminum electrolytic, $\leq 0.3\Omega$ ESR @ 100kHz	Matsushita Electric/ECA-1CFQ121
D1	1.0A	Reverse breakdown ≥ 50 V, surge current ≥ 30 A for 8.3mS, reverse recovery ≤ 200 nS	1N4935
L1, L3	1.0mH	$\pm 10\%$, $I_{max} \geq 30$ mA, $R_{DC} \leq 50\Omega$	TAIYO YUDEN /LAL03NA102K

9. 240VAC, Power Entry Transformer-Isolated Coupling Circuit with Phase Coupling

The transformer-isolated, power entry coupling circuit shown in figure 13 is intended for use close to the power entry and main circuit breaker panel of a house. Typically this circuit would be installed in or next to an electrical meter. Included in the circuit is phase coupling between Line1 and Line2. Table 7 lists component values and recommended suppliers/part numbers where appropriate.

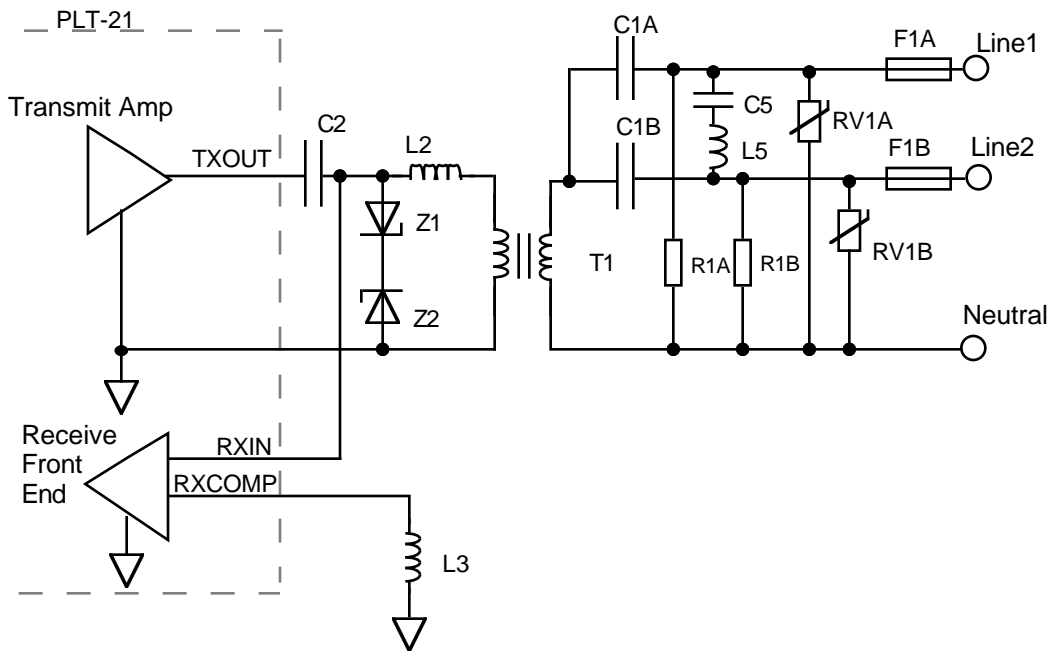

Figure 13 240VAC, Power Entry Transformer-Isolated Phase Coupling Schematic

Table 7 240VAC, Power Entry Transformer-Isolated Phase Coupling Component Values

Comp	Value	Specifications	Vendor/Part #
C1A, C1B	0.047 μ F	$\pm 10\%$, ≥ 250 VDC, metalized polyester ⁽¹⁾	Matsushita Electric/ECQ-E2473KF
C2	0.82 μ F	$\pm 5\%$, ≥ 50 VDC, metalized polyester	Matsushita Electric/ECQ-V1H824JL
C5	0.47 μ F	$\pm 10\%$, ≥ 400 VDC, metalized polyester ⁽¹⁾	Matsushita Electric/ECQ-E4474KF
F1A, F1B	6A	125VAC, slow blow ⁽²⁾	
L2	4.7 μ H	$\pm 10\%$, $I_{max} \geq 500$ mA, $R_{DC} \leq 0.4\Omega$	TAIYO YUDEN /LAL04NA4R7K
L3	1.0mH	$\pm 10\%$, $I_{max} \geq 30$ mA, $R_{DC} \leq 50\Omega$	TAIYO YUDEN /LAL03NA102K
L5	3.3 μ H	$\pm 10\%$, $I_{max} \geq 500$ mA, $R_{DC} \leq 0.4\Omega$	TAIYO YUDEN /LAL04NA3R3K
R1A, R1B	1M Ω	$\pm 5\%$, 1/4W, max working volt ≥ 200 VDC ⁽³⁾	
RV1A, RV1B	150VAC (240VDC)	≥ 14 mm varistor	Matsushita Electric / ERZ-V14D241
T1		See Appendix A	
Z1, Z2	7.5V	$\pm 5\%$ Zener, 180W surge for 8.3ms	1N5343B

- (1) In some applications an X2 safety rated capacitor may be required. Consult applicable safety standards.
- (2) In some applications a fuse may not be required. Consult applicable safety standards.
- (3) The working voltage rating of R1A, R1B may be achieved by using two 470k Ω resistors in series, each with a working voltage rating of at least half of the value listed above.

10. 240VAC, Power Entry Non-Isolated Coupling Circuit with Phase Coupling

The non-isolated, power entry coupling circuit shown in figure 14 is intended for use close to the power entry and main circuit breaker panel of a house. Typically this circuit would be installed in an electrical meter. Included in the circuit is phase coupling between Line1 and Line2. Table 8 lists component values and recommended suppliers/part numbers where appropriate.

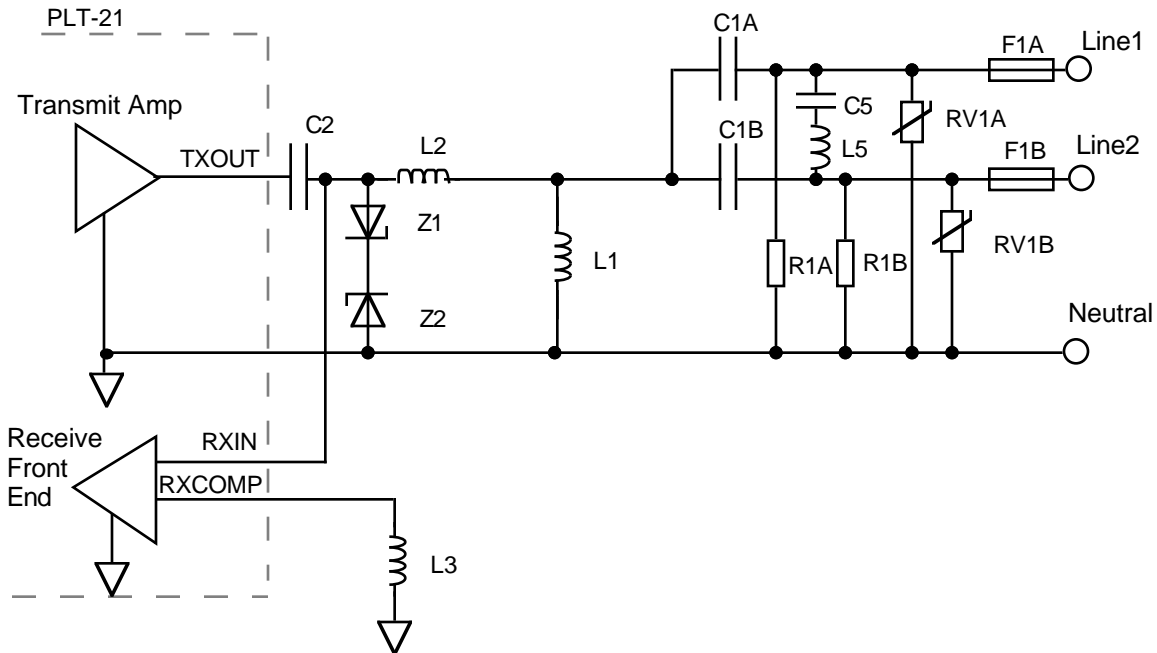

Figure 14 240VAC, Power Entry Non-Isolated Phase Coupling Schematic

Table 8 240VAC, Power Entry Non-Isolated Phase Coupling Component Values

Comp	Value	Specifications	Vendor/Part #
C1A, C1B	0.047 μ F	$\pm 10\%$, ≥ 250 VDC, metalized polyester ⁽¹⁾	Matsushita Electric/ECQ-E2473KF
C2	0.82 μ F	$\pm 5\%$, ≥ 50 VDC, metalized polyester	Matsushita Electric/ECQ-V1H824JL
C5	0.47 μ F	$\pm 10\%$, ≥ 400 VDC, metalized polyester ⁽¹⁾	Matsushita Electric/ECQ-E4474KF
F1A, F1B	6A	125VAC, slow blow ⁽²⁾	
L2	18 μ H	$\pm 10\%$, $I_{max} \geq 500$ mA, $R_{DC} \leq 0.3\Omega$	TAIYO YUDEN /LAL05NA180K
L1, L3	1.0mH	$\pm 10\%$, $I_{max} \geq 30$ mA, $R_{DC} \leq 50\Omega$	TAIYO YUDEN /LAL03NA102K
L5	3.3 μ H	$\pm 10\%$, $I_{max} \geq 500$ mA, $R_{DC} \leq 0.4\Omega$	TAIYO YUDEN /LAL04NA3R3K
R1A, R1B	1M Ω	$\pm 5\%$, 1/4W, max working volt ≥ 200 VDC ⁽³⁾	
RV1A, RV1B	150VAC (240VDC)	≥ 14 mm varistor	Matsushita Electric / ERZ-V14D241
Z1, Z2	7.5V	$\pm 5\%$ Zener, 180W surge for 8.3ms	1N5343B

- (1) In some applications an X2 safety rated capacitor may be required. Consult applicable safety standards.
- (2) In some applications a fuse may not be required. Consult applicable safety standards.
- (3) The working voltage rating of R1A, R1B may be achieved by using two 470k Ω resistors in series, each with a working voltage rating of at least half of the value listed above.

11. Line-to-Line Power Entry Passive Signal Coupler

The circuit shown in figure 15 is intended to couple communication signals from Line1 to Line2, and may be installed close to the power entry and main circuit breaker panel of a house for improved communication margin. Table 9 lists component values and recommended suppliers/part numbers where appropriate.

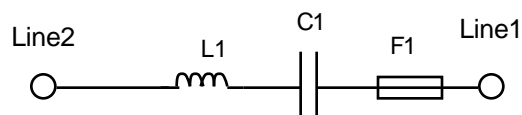

Figure 15 L-to-L Power Entry Passive Signal Coupler Schematic

Table 9 L-to-L Power Entry Passive Signal Coupler Component Values

Comp	Value	Specifications	Vendor/Part #
C1	0.47 μ F	$\pm 10\%$, ≥ 400 VDC, metalized polyester ⁽¹⁾	Matsushita Electric/ECQ-E4474KF
F1	min 3.0A	250VAC, slow blow ⁽²⁾	
L1	3.3 μ H	$\pm 10\%$, $I_{max} \geq 500$ mA, $R_{DC} \leq 0.4\Omega$	TAIYO YUDEN/LAL04NA3R3K

- (1) In some applications an X2 safety rated capacitor may be required. Consult applicable safety standards.
- (2) In some applications a fuse may not be required. Consult applicable safety standards.

12. 240VAC, Distribution Transformer Secondary Transformer-Isolated Coupling Circuit

The transformer-isolated, distribution transformer secondary coupling circuit shown in figure 16 is intended for use at the secondary connection to a distribution transformer. Note that this circuit differs slightly from power entry coupling circuit #9 as it has been modified to account for the effect of secondary wiring inductance between the distribution transformer and the power entry point. Table 10 lists component values and recommended suppliers/part numbers where appropriate.

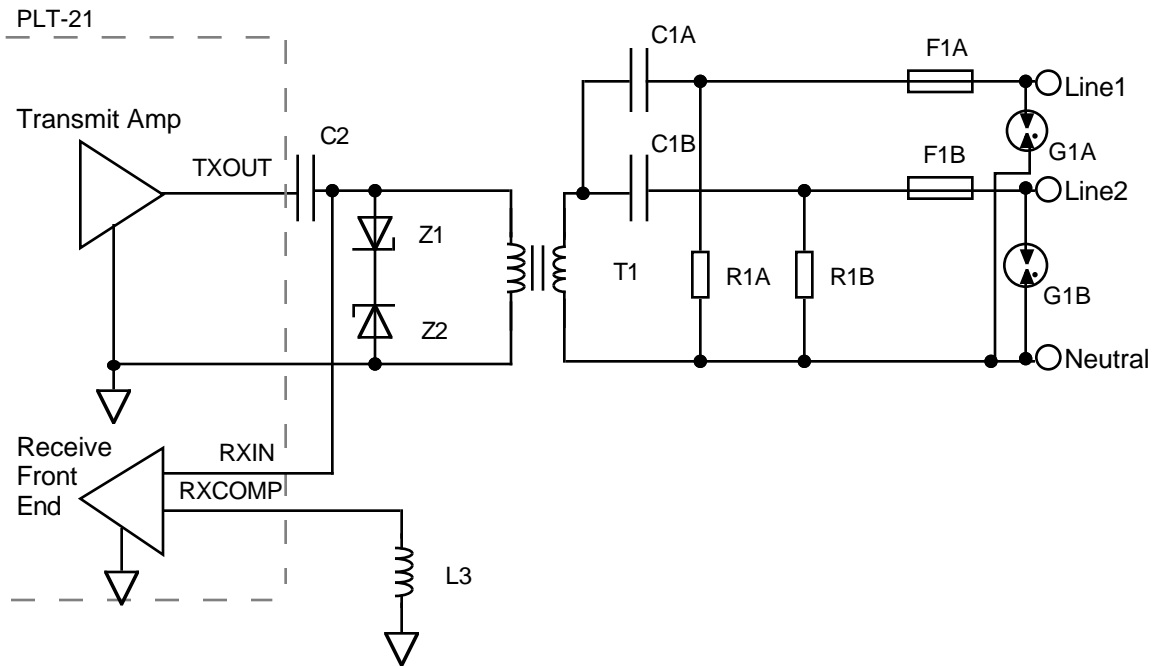

Figure 16 240VAC, Distribution Transformer Secondary Transformer-Isolated Coupling Circuit Schematic

Table 10 240VAC, Distribution Transformer Secondary Transformer-Isolated Coupling
Circuit Component Values

Comp	Value	Specifications	Vendor/Part #
C1A, C1B	0.047 μ F	\pm 10%, \geq 250VAC, X2 type	Nissi Denki/Arcotronics R40473K275XXXX
C2	0.82 μ F	\pm 5%, \geq 50VDC, metalized polyester	Matsushita Electric/ECQ-V1H824JL
F1A, F1B	6A	125VAC, slow blow ⁽¹⁾	
L3	1.0mH	\pm 10%, $I_{max} \geq 30mA$, $R_{DC} \leq 50\Omega$	TAIYO YUDEN /LAL03NA102K
R1A, R1B	1M Ω	\pm 5%, 1/4W, max working volt \geq 200VDC ⁽²⁾	
T1		See Appendix A	
Z1, Z2	7.5V	\pm 5% Zener, 180W surge for 8.3ms	1N5343B
G1A, G1B	120VAC	AC gas discharge tube	CPClare/AC120L

- (1) In some applications a fuse may not be required. Consult applicable safety standards.
- (2) The working voltage rating of R1A, R1B may be achieved by using two 470k Ω resistors in series, each with a working voltage rating of at least half of the value listed above.

13. 240VAC, Distribution Transformer Secondary Non-Isolated Coupling Circuit

The non-isolated, distribution transformer secondary coupling circuit shown in figure 17 is intended for use at the secondary connection to distribution transformer when safety isolation in the coupling circuit is not required. Table 11 lists component values and recommended suppliers/part numbers where appropriate.

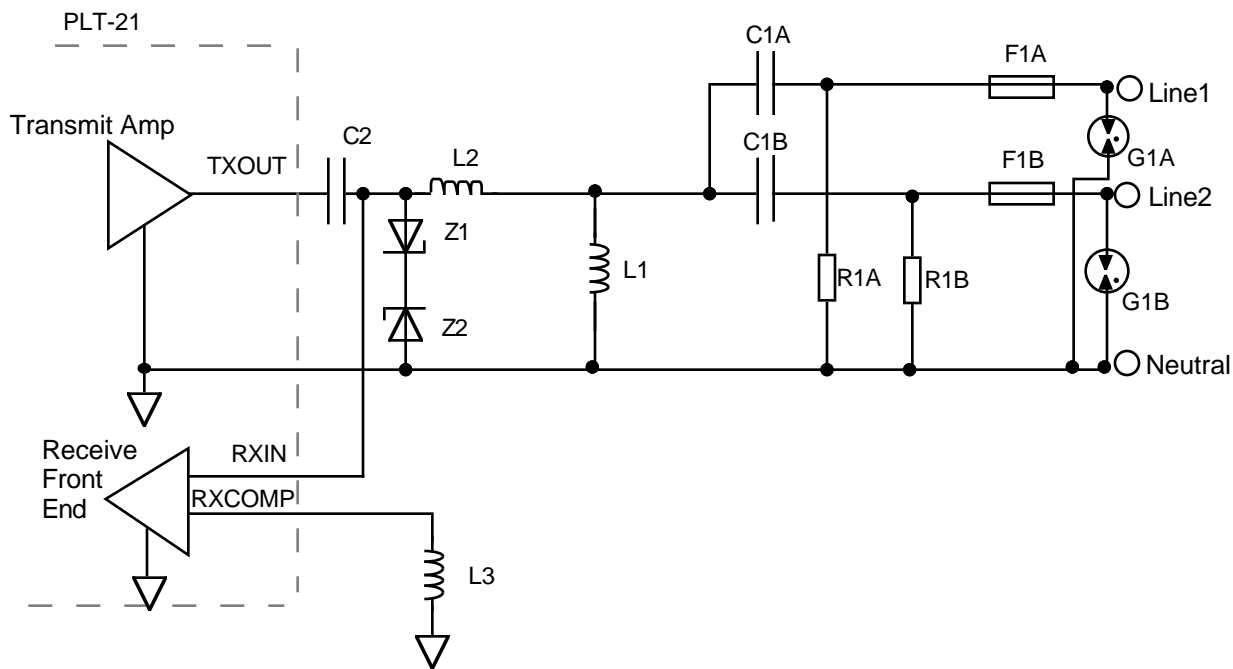

Figure 17 240VAC Distribution Transformer Secondary Non-Isolated Coupling Circuit Schematic

Table 11 240VAC, Distribution Transformer Secondary Non-Isolated Coupling Circuit Component Values

Comp	Value	Specifications	Vendor/Part #
C1A, C1B	0.047 μ F	$\pm 10\%$, ≥ 250 VAC, X2 type	Nissi Denki/Arcotronics R40473K275XXXX
C2	0.82 μ F	$\pm 5\%$, ≥ 50 VDC, metalized polyester	Matsushita Electric/ECQ-V1H824JL
F1A, F1B	6A	125VAC, slow blow ⁽¹⁾	
L2	12 μ H	$\pm 10\%$, $I_{max} \geq 500$ mA, $R_{DC} \leq 0.3\Omega$	TAIYO YUDEN /LAL05NA120K
L1, L3	1.0mH	$\pm 10\%$, $I_{max} \geq 30$ mA, $R_{DC} \leq 50\Omega$	TAIYO YUDEN /LAL03NA102K
R1A, R1B	1M Ω	$\pm 5\%$, 1/4W, max working volt ≥ 200 VDC ⁽²⁾	
Z1, Z2	7.5V	$\pm 5\%$ Zener, 180W surge for 8.3ms	1N5343B
G1A, G1B	120VAC	AC gas discharge tube	CPClare/AC120L

- (1) In some applications a fuse may not be required. Consult applicable safety standards.
- (2) The working voltage rating of R1A, R1B may be achieved by using two 470k Ω resistors in series, each with a working voltage rating of at least half of the value listed above.

Appendix A — PLT-21 Transceiver Isolation Transformer Specifications for 12 μ H of Series Leakage Inductance

This appendix provides a schematic, specifications, and supplier information for a PLT-21 transceiver isolation transformer which includes 12 μ H of series leakage inductance.

PLT-21 Transceiver Isolation Transformer Schematic

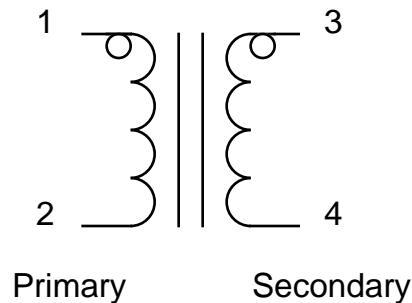

PLT-21 Transceiver Isolation Transformer Electrical Specifications

Below are specifications for the PLT-21 Transceiver Isolation Transformer which includes 12 μ H of series leakage inductance.

<i>Parameter</i>	<i>Min</i>	<i>Typ</i>	<i>Max</i>	<i>Units</i>
Turns Ratio (1-2) : (3-4)		1.0		
DC Resistance				
1-2			0.20	Ohm
3-4			0.20	Ohm
Magnetizing Inductance 1-2 Dry, @100kHz, 1Vrms	0.75	1.0	1.25	mH
Magnetizing Inductance 1-2, Wet, @100kHz, 1Vrms, plus 15mADC	0.75			mH
Leakage Inductance 1-2 (3-4 shorted) @100kHz, 1Vrms	10.8	12.0	13.2	μ H
Winding Capacitance 1-2			30	pF
Winding to Winding Capacitance 1-2 shorted to 3-4 shorted			30	pF

PLT-21 Transceiver Isolation Transformer Vendors

Contact vendors for details on operating temperature ranges, storage temperature ranges, safety agency compliance, mechanical design information, and pricing.

<i>Vendor</i>	<i>Part Number</i>	<i>Contact Instructions</i>
Precision Components, Inc. 400 W. Davy Ln. Wilmington, Illinois 60481	0505-0671	Telephone: +1-630-980-6448 Fax: +1-630-980-6485
EXCEL Electric Corporation 6501 N.W. 13th Court Plantation, Florida 33313	EXL-165	Telephone: +1-954-581-2330 Fax: +1-954-581-2355

Appendix B — PLT-21 Transceiver Isolation Transformer Specifications for Low Series Leakage Inductance

This appendix provides a schematic, specifications, and supplier information for a PLT-21 transceiver isolation transformer which has low series leakage inductance.

PLT-21 Transceiver Isolation Transformer Schematic

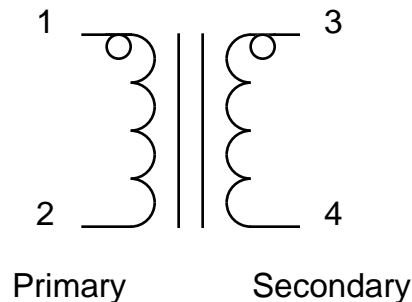

PLT-21 Transceiver Isolation Transformer Electrical Specifications

Below are specifications for the PLT-21 Transceiver Isolation Transformer which includes which has low series leakage inductance.

<i>Parameter</i>	<i>Min</i>	<i>Typ</i>	<i>Max</i>	<i>Units</i>
Turns Ratio (1-2) : (3-4)		1.0		
DC Resistance				
1-2			0.50	Ohm
3-4			0.50	Ohm
Magnetizing Inductance 1-2 Dry, @100kHz, 1Vrms	1.1		1.8	mH
Magnetizing Inductance 1-2, Wet, @100kHz, 1Vrms, plus 45mADC	1			mH
Leakage Inductance 1-2 (3-4 shorted) @100kHz, 1Vrms			1	μH
Winding Capacitance 1-2			25	pF
Winding to Winding Capacitance 1-2 shorted to 3-4 shorted			50	pF

PLT-21 Transceiver Isolation Transformer Vendor

Contact the vendor for details on operating temperature ranges, storage temperature ranges, safety agency compliance, mechanical design information, and pricing.

<i>Vendor</i>	<i>Part Number</i>	<i>Contact Instructions</i>
Precision Components, Inc. 400 W. Davy Ln. Wilmington, Illinois 60481	0505-0569	Telephone: +1-630-980-6448 Fax: +1-630-980-6485

Related Documents

Echelon LONWORKS Product Data Book; Echelon

LONWORKS PLT-20 Power Line Transceiver User's Guide; Echelon

LONWORKS PLT-21 Power Line Transceiver User's Guide; Echelon

LONWORKS PLCA-20 Power Line Communication Analyzer User's Guide; Echelon

LONWORKS PLCA-21 Power Line Communication Analyzer User's Guide; Echelon

Centralized Commercial Building Applications with the LONWORKS PLT-21 Power Line Transceiver; Echelon

LONWORKS PLA-21 Power Line Amplifier Specification and User's Guide

Disclaimer

Echelon Corporation assumes no responsibility for any errors contained herein.
No part of this document may be reproduced, translated, or transmitted in any form without permission from Echelon.

Part Number 005-0070-01 Rev. B

© 1996 Echelon Corporation. Echelon, LON, LONWORKS, Neuron, 3150, 3120, LonBuilder, LonTalk, and LonManager are U.S. registered trademarks of Echelon Corporation. Some of the LONWORKS products are patented and are subject to licensing Terms and Conditions. For a complete explanation, please call 1-800-258-4LON.

Echelon Corporation
4015 Miranda Avenue
Palo Alto, CA 94304
Telephone (415) 855-7400
Fax (415) 856-6153

<http://www.lonworks.echelon.com>

Echelon Europe Ltd
Elsinore House
77 Fulham Palace Road
London W6 8JA
England
Telephone +44-181-324-1800
Fax +44-181-563-7055

Echelon Japan K.K.
Kamino Shoji Bldg. 8F
25-13 Higashi-Gotanda 1-chome
Shinagawa-ku, Tokyo 141
Telephone (03) 3440-7781
Fax (03) 3440-7782