

Application Note

Overweight Indicator

AN-CM-261

Abstract

This application note introduces the implementation of a load cell to indicate overweight. It was based on the Wheatstone bridge network principle. This overweight indicator can be used in multiple applications such as airline baggage limit, elevator capacity, etc. In this app note we will use strain gauges as the weight sensor, SLG88104 as differential amplifier, and SLG46140V GreenPAK as ADC and signal conditioning. If the weight is over 60 Kg, SLG46140V will sound an alarm with 1 Hz frequency.

This application note comes complete with design files which can be found in the References section.

Overweight Indicator

Contents

Abstract 1

Contents 2

Figures..... 2

Tables 2

1 Terms and Definitions..... 3

2 References 3

3 Introduction..... 4

4 Design Approach..... 5

 4.1 Feedback Input 6

 4.2 Control Gain 8

 4.3 Low Pass Filter..... 10

 4.4 GreenPAK Design Component 11

5 Result..... 14

Conclusion 14

Revision History 15

Figures

Figure 1: Flow or State Diagram of System 5

Figure 2: Sensor Load Cell..... 6

Figure 3: Electronics Circuit Sensor & Instrumentation Amplifier..... 7

Figure 4: Wheatstone Bridge Circuit 7

Figure 5: Differential Amplifier Circuit..... 8

Figure 6: Resistor Gain..... 9

Figure 7: Actual Hardware (Development Kits) 9

Figure 8: ADC Module GreenPak Design 10

Figure 9: Low Pass Filter..... 11

Figure 10: Counter Delay and ADC Module..... 11

Figure 11: Gain Setting..... 12

Figure 12: Counter Data Setting for ADC Comparison 12

Figure 13: Counter Setting for Waiting Time 13

Figure 14: Logic Control Delay & ADC 13

Tables

Table 1: Data Resistor Value and Max Kg 14

Overweight Indicator

1 Terms and Definitions

ADC Module	Analog to digital converter module to convert analog signal voltage to weight scale
Sound Alert	Sound made to indicate weight limit

2 References

For related documents and software, please visit:

<https://www.dialog-semiconductor.com/products/greenpak>.

Download our free **GreenPAK™** Designer software [1] to open the .gp files [2] and view the proposed circuit design. Use the **GreenPAK** development tools [3] to freeze the design into your own customized IC in a matter of minutes. Dialog Semiconductor provides a complete library of application notes [4] featuring design examples as well as explanations of features and blocks within the Dialog IC.

- [1] [GreenPAK Designer Software](#), Software Download and User Guide, Dialog Semiconductor
- [2] [AN-CM-261 Overweight Indicator.gp](#), **GreenPAK** Design File, Dialog Semiconductor
- [3] [GreenPAK Development Tools](#), **GreenPAK** Development Tools Webpage, Dialog Semiconductor
- [4] [GreenPAK Application Notes](#), **GreenPAK** Application Notes Webpage, Dialog Semiconductor
- [5] SLG46140V, Datasheet, Dialog Semiconductor.
- [6] SLG88103/4, Datasheet, Rail to Rail I/O 375 nA/Amp.
- [7] AN-1056 Macro circuit design ADC PWM

Overweight Indicator

3 Introduction

The main goal of this application is to measure the weight of an object then indicate with an alarm sound in case of overweight. Input of the system comes from a load cell. Input is an analog signal that has been amplified by a differential amplifier. The analog signal is converted to a digital signal using an ADC. The value of the ADC reading result is then compared to a certain value that is set so that it represents the desired load limit. If an overweight occurs, then the alert turns on with a frequency of 1 Hz. In this app note, we will use a strain gauge as the weight sensor, SLG88104 as the differential amplifier, and SLG46140V as ADC and signal conditioning. The system can be proven by applying a load exceeding the desired load limit (60 Kg). System functionality is correct if at that condition the alarm is on with a frequency of 1 Hz.

The key advantages of designing with **GreenPAK** is that the product is smaller, lower cost, simpler, and easy to develop. **GreenPAK** has a simple GUI interface in **GreenPAK Designer**, allowing engineers to quickly and easily implement new designs and respond to changing design requirements. If we want to develop it further, this solution is an excellent choice. Using **GreenPAK** makes this design very simple, light weight, and only a small area occupied to implement it on most applications. Because of the internal circuit resources available within **GreenPAK**, this design can be enhanced with more features without having to add too many additional IC's. To verify the functionality of this system, we just need to implement the circuit designed with the **GreenPAK** simulation tool.

Overweight Indicator

4 Design Approach

A key idea of this design is to facilitate the calibration of weight on a digital scale, as illustrated in the diagram below. Suppose there are four states to describe how this system works.

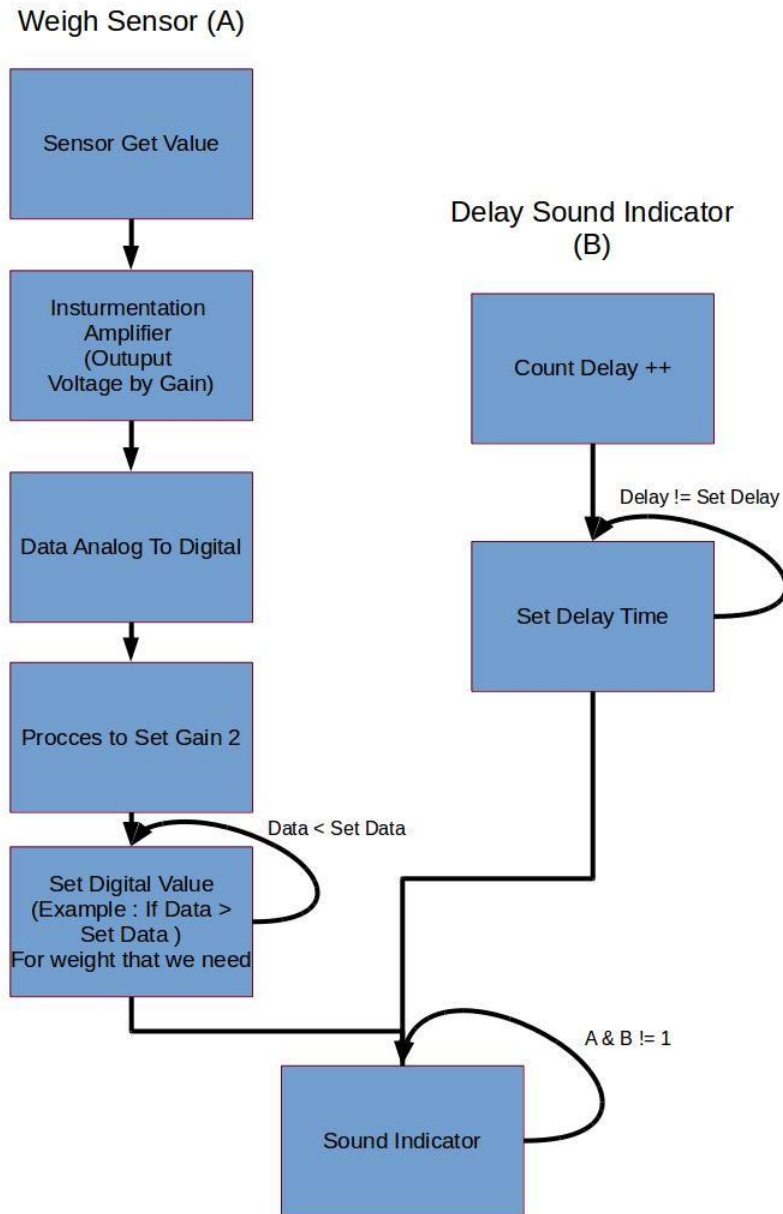

Figure 1: Flow or State Diagram of System

The system has a typical Weight Sensor Section (A), and then does a conversion of Analog to Digital data. Sensors typically generate very low-level analog values and can be processed more easily after conversion into digital signals. The signal to be used will have readable digital data. The data obtained in digital form can be reprocessed into the desired digital value (for heavy or light objects). To indicate the state of the final value, we use a buzzer, but it can be changed easily. For a voice

Overweight Indicator

indicator, one can use a well-known blink (Delay Sound Indicator (B)). In this experiment we used an existing scale having four load cell sensors connected using the Wheatstone bridge principle. As for the LCD already on digital scales, it is left only for validation of the value generated with existing scales.

4.1 Feedback Input

Input feedback for this system comes from the pressure obtained by the sensor to provide an analog signal in the form of a very low voltage but can still be processed into weight scales data.

The simplest circuit of the digital scanning sensor is made from a simple resistor that can change its resistance value according to the weight / pressure applied. The sensor circuit can be seen in [Figure 2](#).



Figure 2: Sensor Load Cell

From this digital scale we make use of four load cell sensors. The sensors that are placed at each corner of the scale will provide accurate values for the total input. The main components of the sensor resistors can be assembled into bridges that can be used to measure each sensor. This circuit is commonly used in digital circuits that use four sources that are interdependent. We only use the four sensors embedded on a scale for our experiments, and pre-embedded systems on this scale such as LCD and the controller are only kept for validating our design. The circuits we used can be seen in [Figure 3](#).

Overweight Indicator

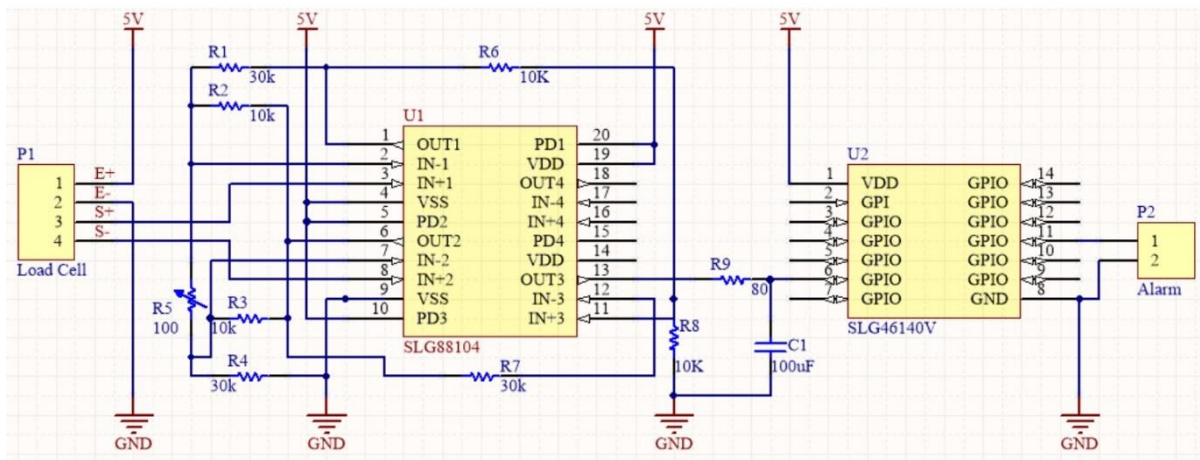
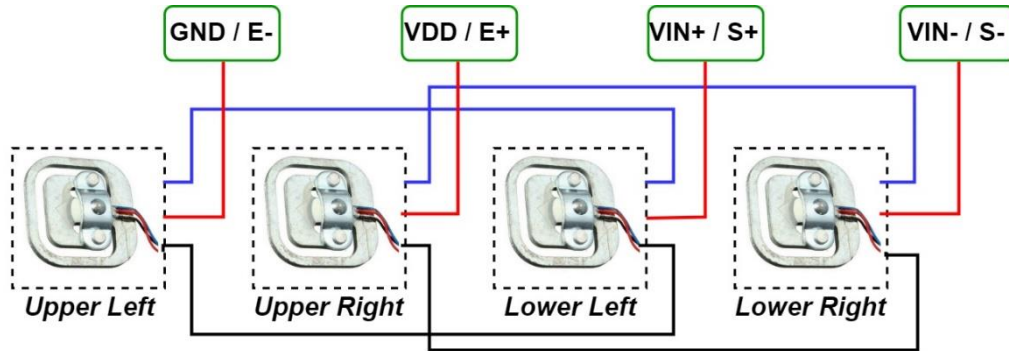

Figure 3: Electronics Circuit Sensor & Instrumentation Amplifier

A Wheatstone bridge is typically used for calibrating measurement instruments. The advantages of a Wheatstone bridge is that it can measure very low values in the milli-ohm range. Because of this, digital scales with fairly low resistance sensors can be very reliable. We can see formula and Wheatstone bridge circuit in Figure 4.

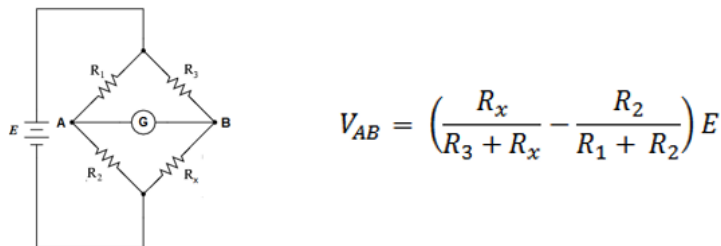
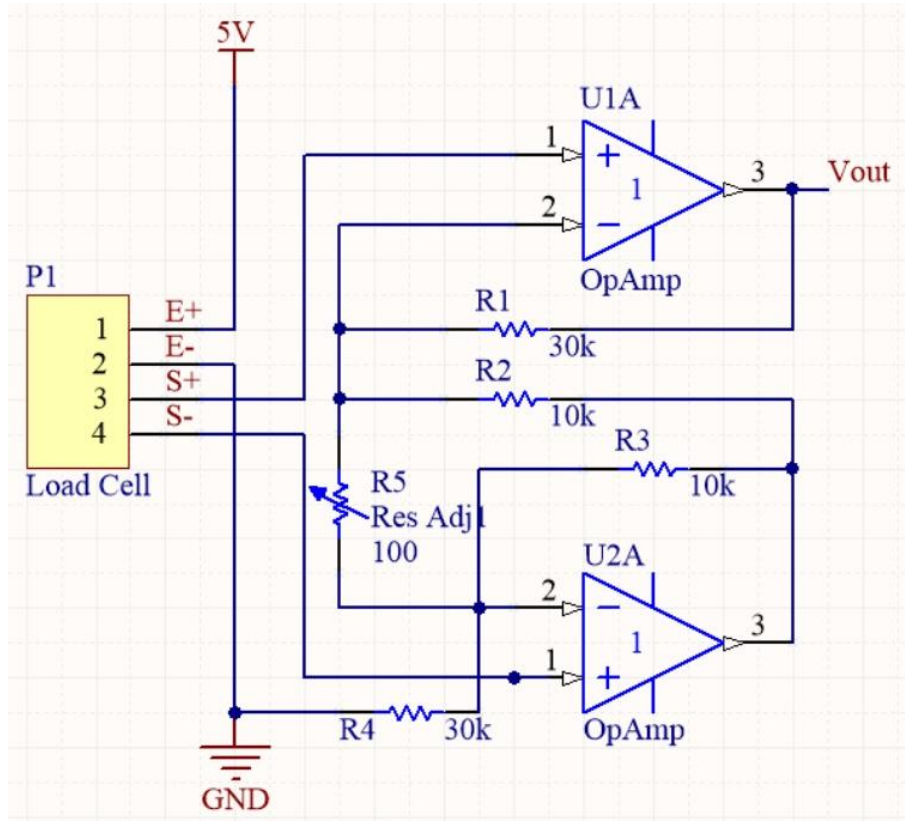

Figure 4: Wheatstone Bridge Circuit

Because the voltage is so small we need an instrumentation amplifier so that the voltage is amplified enough to be read by a controller.

The feedback voltage obtained from the input instrumentation amplifier is processed into a voltage that can be read by the controller (0 to 5 volts in this design). We can appropriately adjust the gain by setting the gain resistor in the SLG88104 circuit. Figure 5 shows the formula to determine the output voltage of the SLG88104 circuit that was used.

Overweight Indicator



$$V_O = (V_{IN}^+ - V_{IN}^-) G$$

$$G = 4 + \frac{60k\Omega}{R_G}$$

Figure 5: Differential Amplifier Circuit

From this formula, the gain relationship is described. If the value of the gain resistor is increased, then the gain obtained will be lower, and vice versa if the gain resistor value is decreased. The output response will be quite accentuated even if the increase or decrease in value is small. Digital scales can become more sensitive to the input (with only a little weight, the value has changes dramatically), or vice versa if the added sensitivity decreases. This can be seen in the result section.

4.2 Control Gain

This is a design that can control the gain again after going through the hardware gain calibration process (gain resistor calibration). From the weight sensor section (A) design, when the data obtained from the instrument amplifier, the data can be processed again so that the gain can be more easily set. The advantage is that we can avoid a hardware gain resistor change.

Overweight Indicator

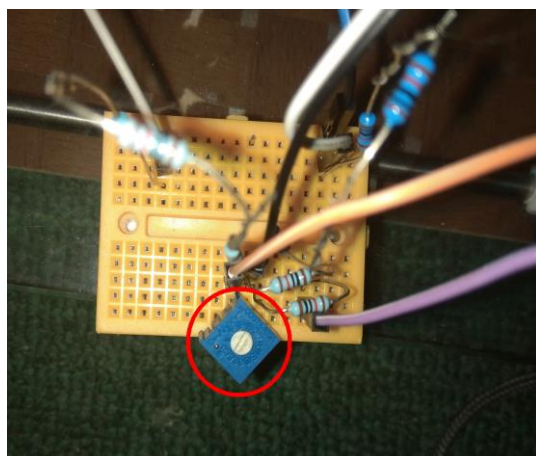
**Figure 6: Resistor Gain**

In [Figure 5](#), with the ADC module there is a PGA that can adjust the gain before the analog value is changed to digital. We provide the input reference from the Vout output of the SLG88104 circuit. The PGA gain will be set in such a way according to the measurements we need. We use x0.25 gain with single-ended ADC mode. With x0.25 the gain is not so large that the input obtained by the ADC converter can measure the weight of large enough or maximally according to what we have tried using Arduino which is 70 Kg. After that, we use Compare data with CNT2 counter as ADC comparator, so we can know the change with sound indicator. The trick is the comparator we make by means of calibration change of CNT2 value so that when the weight > 60 kg, then the Output of DCMP0 is "1". The Sound indicator will light up with a predetermined frequency using block delay sound indicator so that the block will be logic "1" when the time is 0.5 s. The delay we can set the CNT0 counter data adjust the output period of 500 ms.

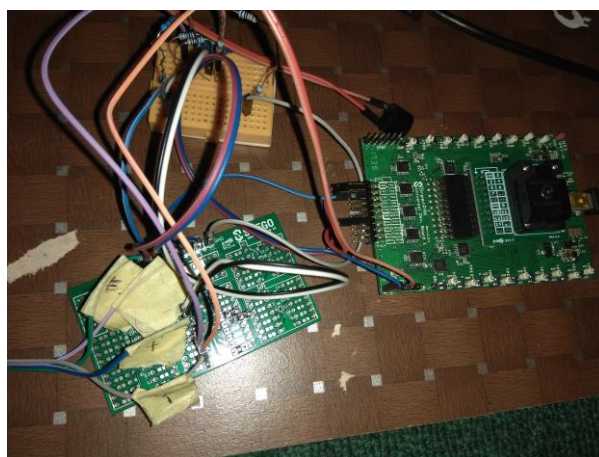
**Figure 7: Actual Hardware (Development Kits)**

Overweight Indicator

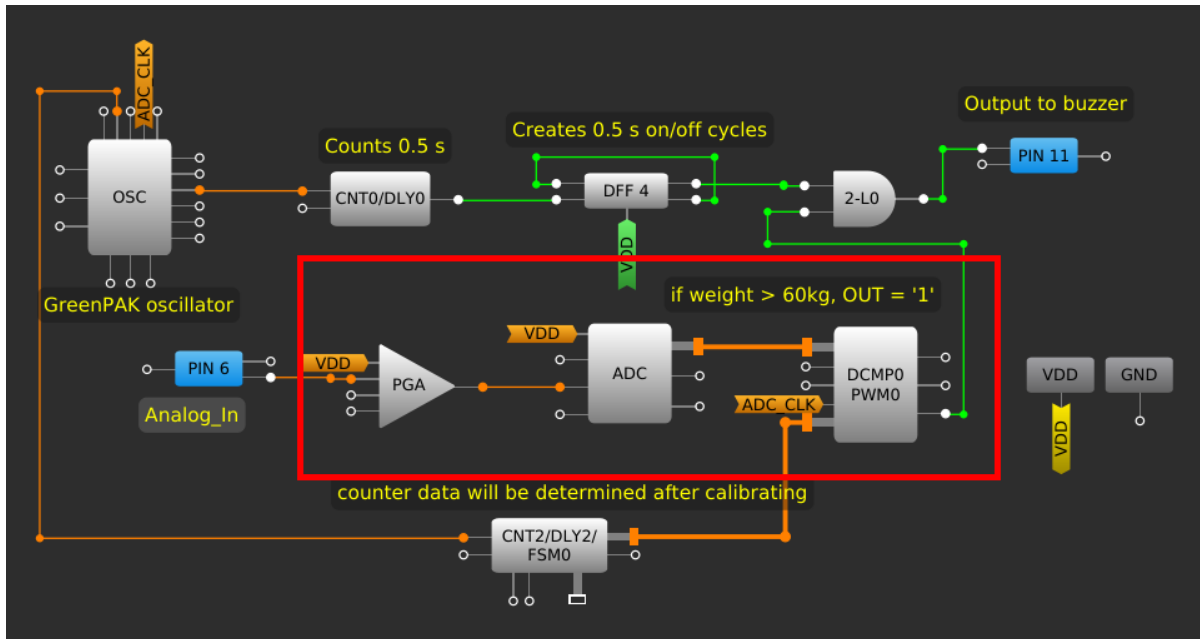

Figure 8: ADC Module GreenPak Design

4.3 Low Pass Filter

It is preferable to filter the differential amplifier output signal. It helps to reject interference and reduces wideband noise. The low pass filter (LPF) implemented reduces unnecessary noise. This simple low-pass filter circuit consists of a resistor in series with a load, and a capacitor in parallel with the load. Some experiments showed the noise component was detectable in the band-pass filter having 32.5- 37.5 Hz passband during frequency spectrum analysis. The cutoff frequency, f_{co} , of the LPF was set to 20 Hz, by using the formula $1.75f_{co} = f_{peak}$. Usually, the capacitors should be very small, for example 100 μ F.

$$f_{co} = \frac{1}{2\pi CR}$$

Obtained R = 80 Ω .

Overweight Indicator

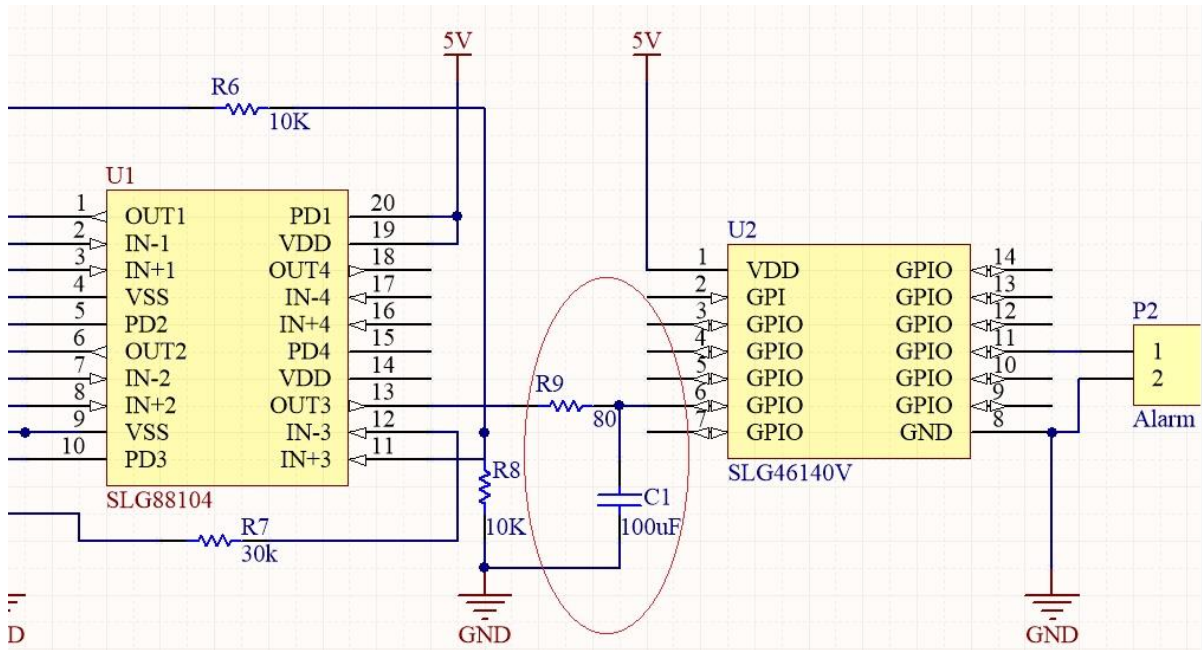

Figure 9: Low Pass Filter

4.4 GreenPAK Design Component

We can see from Figure 8 GreenPAK contains the components we need the ADC module, and Counter for waiting time.

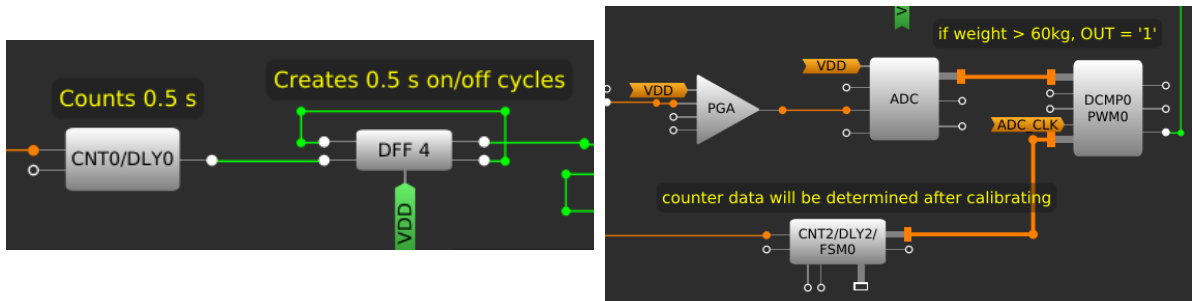

Figure 10: Counter Delay and ADC Module

In the ADC Module section, PGA gain can decrease or increase the gain as needed. The PGA gain has the same function as the gain resistor in the SLG88104 circuit.

Overweight Indicator

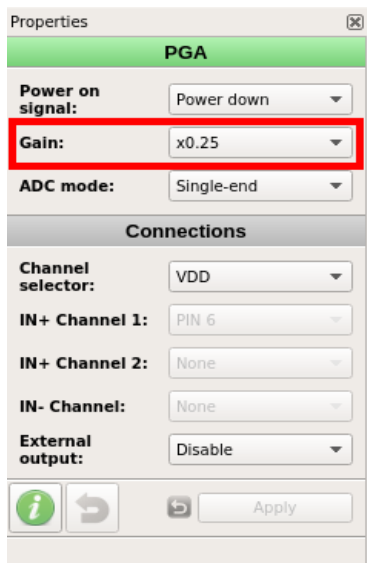

Figure 11: Gain Setting

The output data obtained by the ADC, arranged in such a way by counter calibration data by adding or reducing the counter data value. We can set it according to the hardware we have created and the appropriate weight to be output. For this demo we get and set the counter data value of 250 for 60 kg.

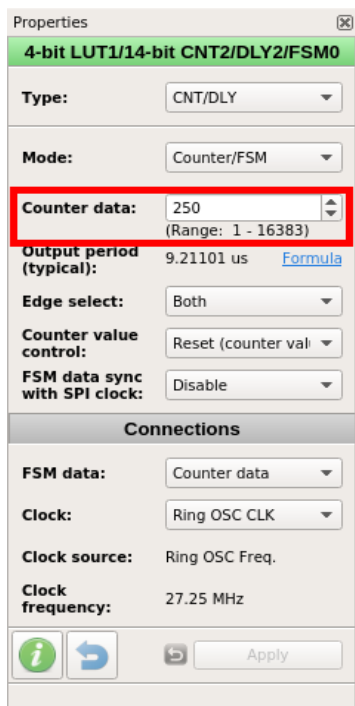

Figure 12: Counter Data Setting for ADC Comparison

The Counter for waiting time is CNT0. Counter data on CNT0 will determine how long the sound indicator will be on. We can set this value as we need. For this demo we use the data counter 3125 for 0.5 s.

Overweight Indicator

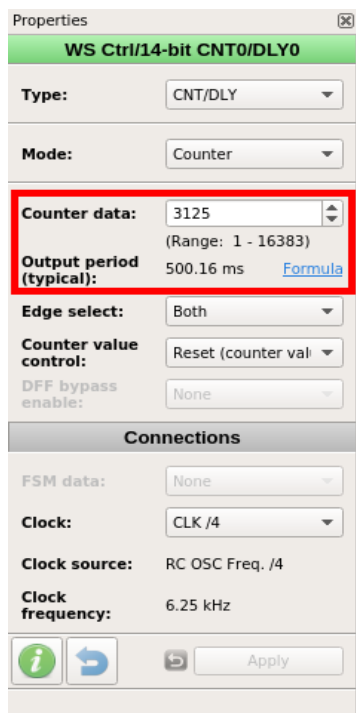

Figure 13: Counter Setting for Waiting Time

We use LUT0 to compare with standard AND gates so that if the exact time of 0.5 s and weight exceeds 60 kg, then the Sound indicator will sound.

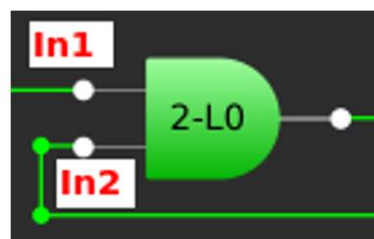

Figure 14: Logic Control Delay & ADC

Overweight Indicator

5 Result

For this simulation we did two tests. First, we try to know the effect of Resistor Gain to the input obtained later to be processed and get the calibration value of the gain resistor that best matches the digital scale made. The second is to make the design using SLG46140 to be able to perfect the gain you want to get.

After the test, we searched for the highest point of resistor value for digital scales to maximize the capability of the amplifier circuit created and the capabilities of the developed digital scales. With this design we get the highest gain resistor value of ± 6.8 Ohm and the maximum weight measured is ± 60 Kg. It is quite complicated to adjust the value of the gain resistor because the design also greatly affects the required gain resistor. For the digital scale used in this example, it has been difficult to exceed 6.8 Ohm in an attempt to achieve higher weight.

Table 1: Data Resistor Value and Max Kg

No	Resistor Value	Max Kg
1	1 Ohm	± 0 kg
2	2 Ohm	± 0 kg
3	4 Ohm	± 0 kg
4	6 Ohm	± 20 kg
5	6.8 Ohm	± 60 kg

Furthermore, from the second test (using SLG46140 and its features), the maximum weight you want to measure can be set using the PGA module that sets the gain. We test with a gain setting $\times 0.25$ and the sound indicator is triggered with weight >60 kg.

Based on the above results, functionally, digital scale calibration goes well. This is very helpful in setting the amplifier compared to manual hardware changes. We also compare favorably in size against a controller that can adjust the amplifier gain calibration and has ADC feature as well. The design advantages presented here include smaller physical size, simplicity, power consumption, price, and easily customizable.

Conclusion

This Overweight indicator using the SLG46140 is an ideal solution for a preset weight indicator. The Dialog Semiconductor [GreenPAK](#) design above is completed by using the SLG88104. The lower comparative cost, small area, low power, along with the ease of programming [GreenPAK](#) makes this stand out compared to a microcontroller design. The Wheatstone bridge, differential amplifier, and adjustable gain principles were demonstrated. This design example can also be extended to other Wheatstone bridge applications, as it is highly reliable on very low resistance instrumentation.

Overweight Indicator

Revision History

Revision	Date	Description
1.0	14-Nov-2018	Initial Version

Overweight Indicator

Status Definitions

Status	Definition
DRAFT	The content of this document is under review and subject to formal approval, which may result in modifications or additions.
APPROVED or unmarked	The content of this document has been approved for publication.

Disclaimer

Information in this document is believed to be accurate and reliable. However, Dialog Semiconductor does not give any representations or warranties, expressed or implied, as to the accuracy or completeness of such information. Dialog Semiconductor furthermore takes no responsibility whatsoever for the content in this document if provided by any information source outside of Dialog Semiconductor.

Dialog Semiconductor reserves the right to change without notice the information published in this document, including without limitation the specification and the design of the related semiconductor products, software and applications.

Applications, software, and semiconductor products described in this document are for illustrative purposes only. Dialog Semiconductor makes no representation or warranty that such applications, software and semiconductor products will be suitable for the specified use without further testing or modification. Unless otherwise agreed in writing, such testing or modification is the sole responsibility of the customer and Dialog Semiconductor excludes all liability in this respect.

Customer notes that nothing in this document may be construed as a license for customer to use the Dialog Semiconductor products, software and applications referred to in this document. Such license must be separately sought by customer with Dialog Semiconductor.

All use of Dialog Semiconductor products, software and applications referred to in this document are subject to Dialog Semiconductor's [Standard Terms and Conditions of Sale](http://www.dialog-semiconductor.com), available on the company website (www.dialog-semiconductor.com) unless otherwise stated.

Dialog and the Dialog logo are trademarks of Dialog Semiconductor plc or its subsidiaries. All other product or service names are the property of their respective owners.

© 2018 Dialog Semiconductor. All rights reserved.

Contacting Dialog Semiconductor

United Kingdom (Headquarters)
Dialog Semiconductor (UK) LTD
Phone: +44 1793 757700

Germany
Dialog Semiconductor GmbH
Phone: +49 7021 805-0

The Netherlands
Dialog Semiconductor B.V.
Phone: +31 73 640 8822

Email:
enquiry@diasemi.com

North America
Dialog Semiconductor Inc.
Phone: +1 408 845 8500

Japan
Dialog Semiconductor K. K.
Phone: +81 3 5769 5100

Taiwan
Dialog Semiconductor Taiwan
Phone: +886 281 786 222

Web site:
www.dialog-semiconductor.com

Hong Kong
Dialog Semiconductor Hong Kong
Phone: +852 2607 4271

Korea
Dialog Semiconductor Korea
Phone: +82 2 3469 8200

China (Shenzhen)
Dialog Semiconductor China
Phone: +86 755 2981 3669

China (Shanghai)
Dialog Semiconductor China
Phone: +86 21 5424 9058